

# Connecting RIP-24 mod.56 (RIP-24-4/40M3-R-RS)

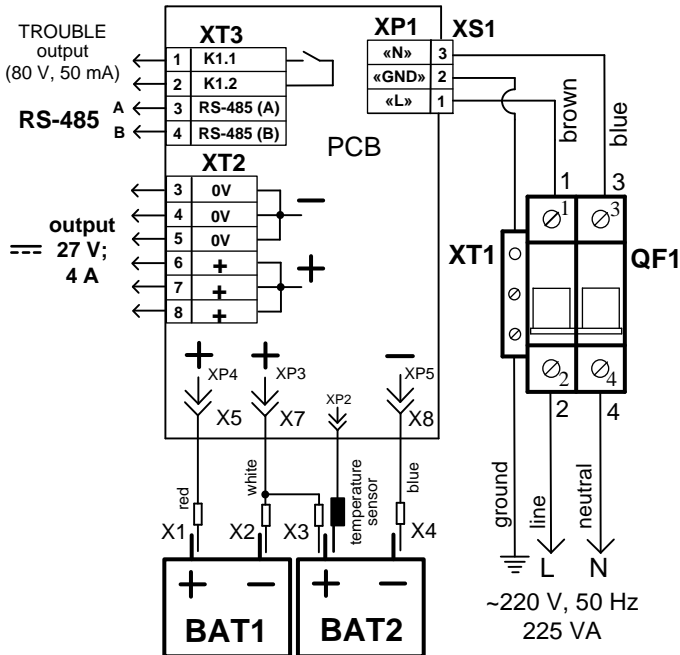

**WARNING**  
**To avoid an electrical shock:**

1. Connect the protection ground to XT1 contact
2. Always do shut off 220V and turn off the QF1 circuit breaker prior to installing or replacing backup batteries

## How to Turn the Power Supply On

1. Connect the batteries as shown in the diagram
2. Connect the RIP to the mains (with the hot wire to QF1:2) and apply external power 220V
3. Turn on the QF1 circuit breaker

## How to Turn the Power Supply Off

1. Turn off the external power 220 V
2. Turn off the QF1 circuit breaker
3. Disconnect the leads X1, X2, X3, and X4 from the batteries