

ИСО 9001



**THRESHOLD PHOTOELECTRIC SMOKE DETECTOR
IP212-31 DIP-31**

User's Manual

BOLD[®]

Table of Contents

1	Description and Operation	4
1.1	Purpose	4
1.2	Specifications	5
1.3	Standard Delivery	6
1.4	Design and Operation	6
1.5	Measuring Instruments, Tools, and Accessories	7
1.6	Marking and Sealing	7
1.7	Packaging	8
2	Intended Use.....	8
2.1	Operating Restrictions	8
2.2	Preparing for Use.....	8
3	Maintenance	12
3.1	General	12
3.2	Safety Precautions	12
3.3	Maintenance Procedures	12
3.4	Performance Testing	12
3.5	Technical Examination	13
3.6	Preservation (Depreservation, Represervation).....	13
4	Repair.....	13
5	Storage	13
6	Transporting	13
7	Disposal.....	13
8	Manufacturer Warranty.....	14
9	Certification Information	14

This user's manual explains the principles of operating IP 212-31 DIP-31 Threshold Photoelectric Smoke Detector v.1.05.

Only the personnel who have studied this manual are allowed to operation activities. All activities on mounting, programming and commissioning shall be performed in compliance with the requirements of the regulatory documentation in force at the place of operation.

1 Description and Operation

1.1 Purpose

- 1.1.1 IP 212-31 DIP-31 Threshold Photoelectric Smoke Detector (hereinafter referred to as the detector) is to be used in fire detection and fire alarm systems to detect fires that release smoke in closed premises of buildings by sensing the light reflected by smoke particles and generating a fire alarm automatically.
- 1.1.2 The detector is to be powered via an alarm loop of a control and indicating unit S2000-4, Signal-20P, S2000-ASPT, Signal-10, control and indicating equipment Signal-20M or similar, which provide loop voltage up to 30 V and limit the current in a loop at a level not exceeding 25 mA. A fire alarm is triggered by an increase of the current in the alarm loop of the control and indicating equipment as a result of reducing the equivalent resistance of the detector.
- 1.1.3 The detector is intended for round-the-clock operation.
- 1.1.4 The detector is classified as a recoverable and periodically maintained item.

1.2 Specifications

Table 1.2.1

Parameter	Value
Power supply voltage (in the alarm loop)	10 through 30 V dc
Consumed current: - In the quiescent mode - In the fire alarm mode	140 uA max 10 mA max
Potential number of the detectors that can be brought into an alarm loop of control and indicating equipment mentioned in Clause 1.1.2	At least 35 units
Maximum active resistance of alarm loop wires	100 Ohm max
Minimum insulation resistance between alarm loop wires	50K Ohm min
Start-up time	40 s max
Internal resistance of the detector in the fire alarm mode at the current value: - 8 mA - 2 mA	2.4K Ohm max; 4.2K Ohm max
Immunity to background illumination due to artificial and natural lighting	12,000 lux min
Sensitivity	0.1 dB/m to 0.2 dB/m
Enclosure protection degree as per GOST 14254-2015	IP40
Resistance to mechanical exposure as per OST 25 1099-83	Arrangement Category III
Vibration exposure: - Frequency range - Max acceleration	1-35 Hz (for Category III) 0.5 g (for Category III)
Operating temperature range	Minus 10 to +50°C
Weight	0.1 kg max
Overall dimensions	47 × Ø100 mm
Non-stop operation	24/7
MTBF in the quiescent mode	80,000 hours min
Survival probability	0.98758
Expected lifetime	10 years

As to immunity to electromagnetic interference, the detector meets the requirements of Test Severity Level III as per the standards listed in Annex 'B' of GOST R 53325-2012.

The detector passes the industrial interference standards prescribed for 'B' Class equipment per GOST R 30805.22.

1.3 Standard Delivery

The detectors are delivered in group packages, being packed in ten pieces.
Find the following unpacking a group package (see Table 1.3.1).

Table 1.3.1

Item	Quantity
IP 212-31 DIP-31 Smoke Detector (body)	10 pcs.
IP 212-31 DIP-31 Detector Base	10 pcs.
Accessory Kit:	
Dust Cover	10 pcs.
MK-3 Recessed Mounting Kit *	—
Protection Wire Cage*	—
Documentation	
IP 212-31 DIP-31 Threshold Photoelectric Smoke Detector Operations Manual	1pc.

* – Supplied separately.

1.4 Design and Operation

1.4.1 The detector (Figure 1) comprises the mounting base (Position 1) with guiding grooves (Position 2), two light emitting diode indicators (Position 3), printed circuit board and smoke sensing chamber (Position 4), detector housing (Position 5), detector cover (Position 6), sensing chamber cover (Position 7), and insect screen (Position 8).

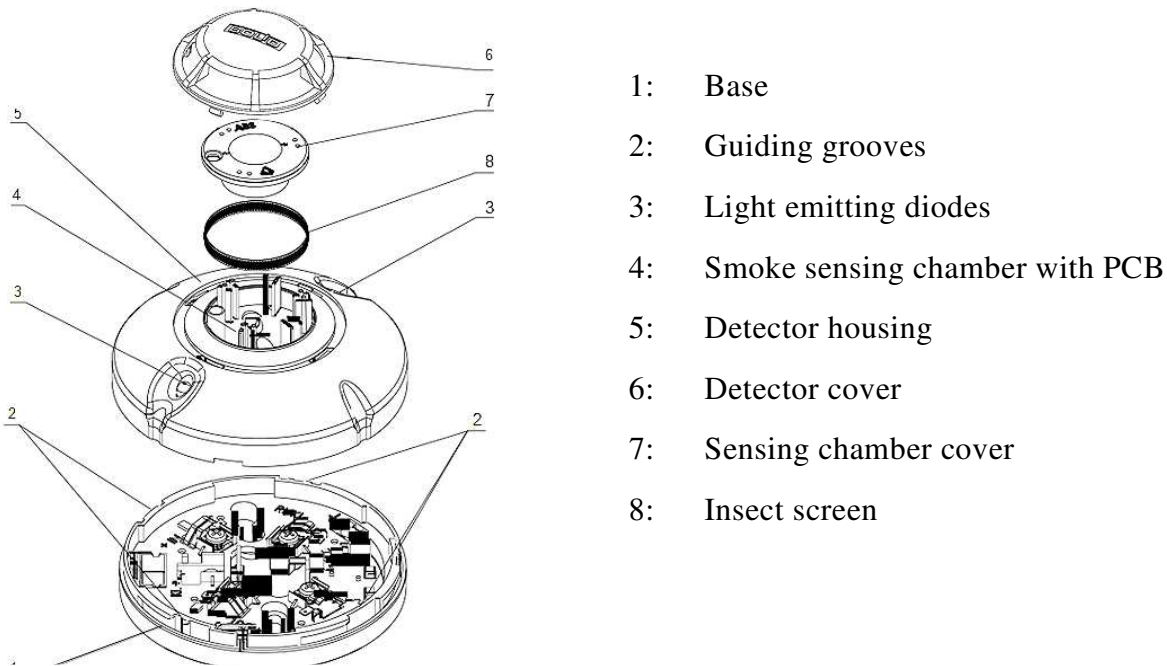

Figure 1

A microcontroller, the smoke sensing chamber, and LED are on the printed circuit board.

By means of the sensing chamber the microcontroller registers the optical emission reflected from smoke particles. As a result of processing the data received from the sensing chamber, the microcontroller issues alarms as their values increase and the threshold is exceeded.

The detector firmware provides correction for slow rise of the background signal in the smoke sensing chamber as a result of dust accumulation on its inside surfaces.

The corrected value of the background signal reaching some threshold defined by the detector (correction is performed every 24 hours), the detector starts indicating with the Contaminated Chamber mode. However, the detector for some time is able to issue a fire alarm in case of increased

smoke content. This gives a time to take measures to clean the detector. Unless the detector is cleaned, then with a further increase in the background signal the “Fault” indication mask will appear and detecting fires will be impossible.

The “Fault” indication mask is given also when the sensitivity of the detector reduces from initial values due to degradation of optical components or pollution.

1.4.2 The microcontroller via its LED gives indication of the detector conditions and also can accept the light produced by a remote laser test unit to its LED.

1.4.3 For testing purposes, the detector can be exposed to the light beam emitted by a laser test unit. System Sensor remote test units, Astra-942 Laser Tester from the TEKO Company, or OT-1 Optical Tester from the RUBEZH Company are acceptable to be used as remote laser testers.

1.4.4 When the smoke content in the smoke sensing chamber reaches the threshold value, the detector enters the Fire Alarm mode. It turns its LEDS on for lighting steadily and increases current consumption up to a level enough for control and indicating equipment to recognize the Fire Alarm conditions.

1.4.5 The detector provides connecting a remote visual alarm (remote indicator), for example VUOS-31, to duplicate operation of the main LED indicators.

Note: A VUOS-31 remote indicator with the red LED (and colour free LED cap) is suitable for testing with a laser tester. Other remote indicators can be not suitable for this purpose.

1.4.6 The detector meets the requirements of Russian codes of practice “CII5.13130.2009”, Annex ‘P’.

1.4.7 The detector can be in one of the following operation modes:

- Quiescent Conditions: The smoke content is in the normal range;
- Prealarm: Two levels of sensing chamber signal measured successively are 75% of the fire condition level each;
- Fire Alarm: The smoke content has exceeded the set fire threshold;
- Contaminated Chamber (Service Required): The sensing chamber is polluted (the signal level has slowly reached 75 percent of the maximum contamination level);
- Fault: The optical channel of the detector is faulty or dirty;
- Initialization: Self-initialization of the detector when switched on.

1.5 Measuring Instruments, Tools, and Accessories

While mounting, commissioning, and maintaining the detector please use the instruments, tools, and accessories shown in Table 1.5.1.

Table 1.5.1

Instrument	Specifications
Digital multimeter	AC/DC voltage up to 500V, AC/DC current up to 5A, resistance up to 2M Ohm
Flat head screwdriver	3.0 × 50 mm
Cross slot screwdriver	2 × 100 mm
Side-cutting pliers	160 mm
Pliers	160 mm

1.6 Marking and Sealing

Every detector has a marking placed on the back side of its body.

The marking contains the name of the detector, its decimal number, factory number, the year and quarter of production, and conformity marks.

1.7 Packaging

The detectors along with accessories kits and operation documentation are packaged in a cardboard box.

2 Intended Use

2.1 Operating Restrictions

The design of the detector doesn't provide its operation in aggressive and dusty environments or in ex-hazardous premises.

Correct performance of the detector cannot be guaranteed if the electromagnetic environment does not meet the requirements defined in the Section 1.2 of this manual.

2.2 Preparing for Use

2.2.1 Safety Precautions

- The design of the detector meets the requirements of electric and fire safety including emergency operation in accordance with Russian standards GOST 12.2.007.0-75 and GOST 12.1.004-91;
- There are no potential hazard circuits within the detector;
- Do SHUT OFF power from the detector before mounting, installing, and maintaining this one;
- Mounting and maintenance of the detector should be carried out by persons with the second or higher electric safety qualification level.

2.2.2 Design

Figure 2 shows the detector's appearance and mounting dimensions for installing the detectors onto a flat surface (Variant A) and for using mounting kits MK-2 or MK-3 to attach the detectors to suspended ceiling tiles (Variant B).

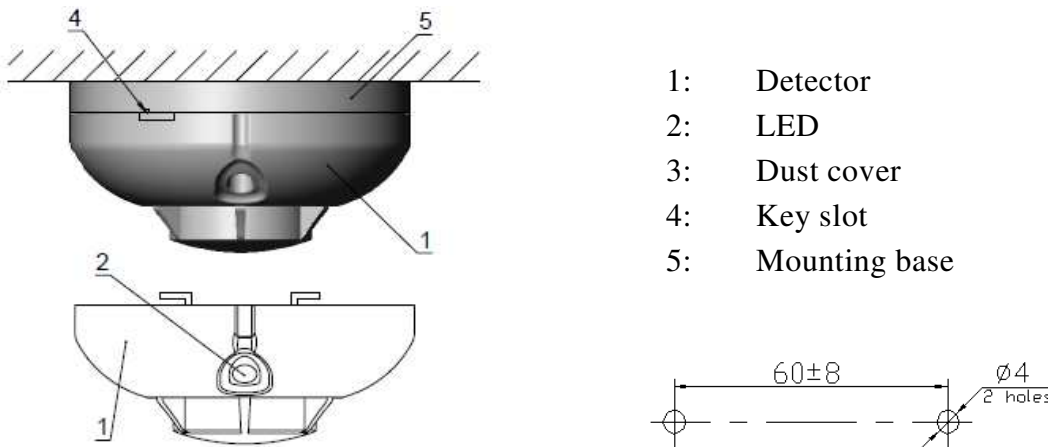

Figure 2

2.2.3 Mounting the Detectors

2.2.3.1 While installing the detectors, please be guided by actual national codes and mounting rules for fire detectors - for example, by the code of practice “CPI 484.1311500.2020”, in particular by the requirements shown in the table 2.

Supervised Room Height, m	Detection Area Radius, m
Up to 3.5	6.40
3.5 ÷ 6.0	6.05
6.0 ÷ 10.0	5.70
10.0 ÷ 12.0	5.35

If it is not possible to install detectors on the flat slab, these ones can be suspended by steel ropes (strings) or installed on walls, columns and other bearing building structures as per Clause 6.6.9 of the code of practice “CPI 484.1311500.2020”.

2.2.3.2 The detector is to be mounted on the surface of bearing structures via its base, which is to be secured to the surface in accordance with the drilling template given in Figure 2.

2.2.3.3 The detectors can also be attached to a suspended ceiling using recessed mounting kits MK-2 or MK-3 (supplied per a separate order).

2.2.3.4 Until installation works are completed, the sensing chamber of the detector should be covered by the protection cover provided.

2.2.3.5 The detector’s design provides protecting the detector against unauthorized removing the detector from its base.

For this purpose, prior to installing the detector into the base, detach the key (Figure 3, Position 3) from it and cut out the rib (Figure 3, Position 1) of the locking click (Figure 3, Position 2).

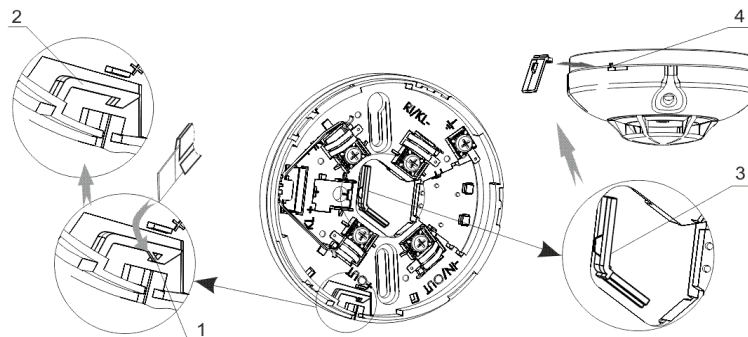

Figure 3

For installing the detector body, place it onto the base as shown in Figure 4 (A) and rotate clockwise until reaching into the guiding grooves. Then rotate it until rest as shown in Figure 4 (B).

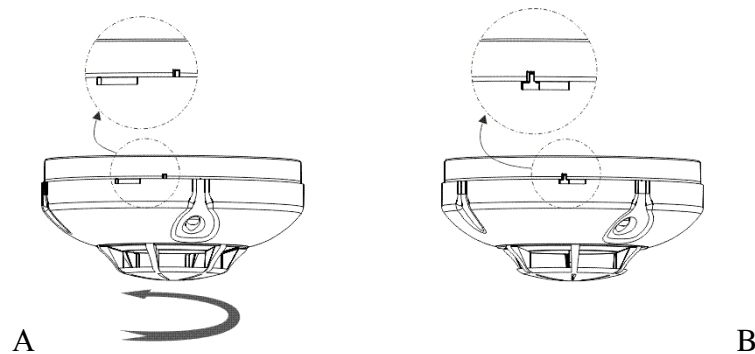

Figure 4

For releasing the detector, insert the key (Figure 3, Position 3) into the slot (Figure 3, Position 4), push inward and in the same time rotate the detector body counterclockwise. Then remove the key

from the slot and rotate the detector body further in the same direction until it is separated from the base.

2.2.3.6 To provide mechanical protection for the detector, please use Protection Wire Cage, to be supplied separately.

2.2.4 Wiring

The detectors, along with VUOS-31 remote indicators or without them, are electrically wired into the alarm loops of control and indicating equipment per the schematic shown in Figure 5.

In general, for generating events Fire Alarm 1 (Pre-Alarm) and Fire Alarm in two-threshold alarm loops, an additional resistor is to be brought in series with the detector. DIP-31 detectors have already had additional resistors built within them, which facilitates mounting the detectors for their operation with fire control and indicating equipment (units) such as Signal-10, S2000-4, Signal-20P, S2000-ASPT, Signal-20M, Signal-20.

While connecting the detectors into alarm loops of fire alarm and control units Signal-10, Signal-20P, S2000-4 and devices Signal-20M, S2000-ASPT as per Figure 5, the following types of alarm loops can be assigned:

- 1: Fire Smoke (two-threshold);
- 2: Fire Combined (single-threshold).

For both cases the end resistor in a loop is $R_t = 4.7K \text{ Ohm}$.

The detector is protected against reverse polarity of connecting into alarm loops.

Wiring shall be carried out with the equipment in de-energized state.

When connecting wires, it is advised to use cable shoes.

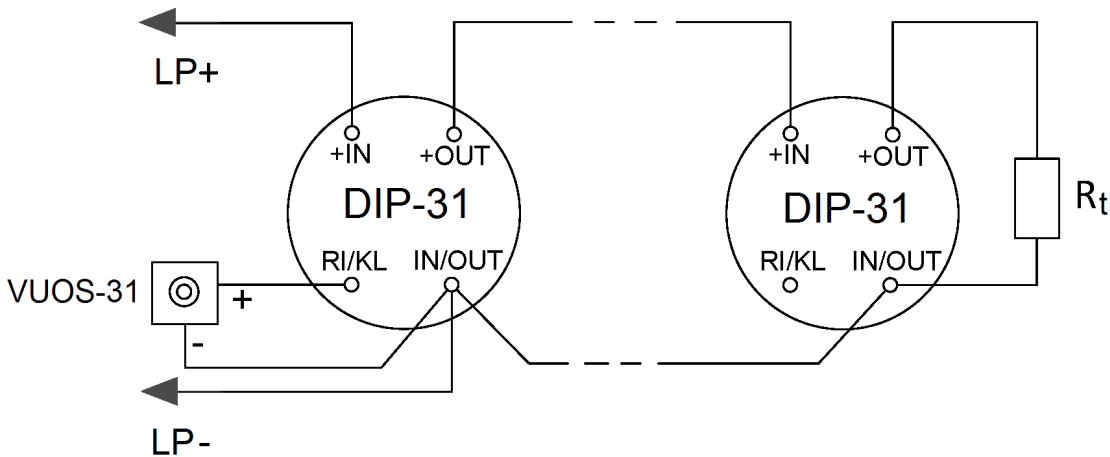

Figure 5

2.2.5 Programming the Detector

For the detector to operate properly, the configuration of the relevant alarm loop of the control and indicating equipment is to be set.

2.2.6 Indication

The detector provides indication of the following conditions by means of two red built-in visual indicators as follows:

- QUIESCENT CONDITIONS: Flashing once every 6 s;
- PREALARM: Two flashes every 6 s
- FIRE ALARM: Light steadily;
- CONTAMINATED CHAMBER: Three flashes every 6 s
- FAULT: Four flashes spaced 200 ms apart every 6 s.

2.2.7 Usage

To be admitted to work with the detector, the personnel are obliged to have studied this manual and to have a certificate of verification of knowledge of safety regulations.

The detector is best suited to operate with control and indicating equipment (units) such as Signal-10, S2000-4, Signal-20P, S2000-ASPT, Signal-20M, Signal-20.

2.2.8 Functional Testing

Perform functional testing as described in Section 3.4 of this manual.

2.2.9 Extreme Situation Actions



WARNING:

If sparks, fire, smoke, or smell of burning is found at the installation site of the detector, the detector must be de-energized and sent for repair

2.2.10 Troubleshooting

Table 2.2.10.1

Fault	Possible Cause	Solution
No LED indication	No power applied	Check the voltage at the relevant contacts of the detector base
The detector being tested, no fire alarms are received by the control and indicating equipment	Improper wiring and settings of the control and indicating equipment	Check wiring and settings of the control and indicating equipment in use
	For this type of the control and indicating equipment the detector cannot provide the required thresholds or response times for the alarm loop	The detector is best suited to operate with control and indicating equipment (units) such as Signal-10, S2000-4, Signal-20P, S2000-ASPT, Signal-20M, Signal-20
The remote indicator does not illuminate	Incorrect wiring of the remote indicator, of short/open failure on its circuit	Check wiring
	The remote indicator has failed	Replace the remote indicator
The remote indicator does not respond to lighting with remote tester's beam to its light emitting diode	The LED in your remote indicator is not suitable for accepting tester beams	Use VUOS-31 as a remote indicator
The detector cannot be detached from its base	The key preventing accidental unscrewing of the detector from the base has been inserted	Remove the key from the slot
The indication mask differs from single flashes	The indication mask represents the internal state of the detector	Check the operation mode of the detector using the descriptions of the indication masks

3 Maintenance

3.1 General

Maintenance works are to be carried out subject to the following schedule:

Table 3.1

Task Description	Frequency
Visual check of the equipment	6 months
Inspecting the equipment for proper operation	Annually

3.2 Safety Precautions

The detector should be maintained by personnel qualified for the Electrical Safety of Level II or higher.

3.3 Maintenance Procedures

3.3.1 Visual check of the detector includes inspecting it for mechanical damage, fastening security, conditions of connecting wires and contact joints. Check the insect screen of the sensing chamber visually for dust. If there is any dust please remove it using a vacuum cleaner (by pumping air).

3.3.2 If the detector indicates the Contaminated Chamber mode, clean the sensing chamber. The description of the dust removing routine can be found online at the Bolid website.

3.3.3 Operability of the detector is to be tested in line with Section 3.4 of this manual.



WARNING!

Removing the detector's PC board from its housing automatically voids the manufacturer's warranty

3.4 Performance Testing

3.4.1 During testing the detector, disable the outputs of the control and indicating equipment that control fixed fire suppression systems, and notify the proper authorities.

3.4.2 Turn the network controller and the control and indicating unit on, the detector entering the Initialization mode. Soon thereafter the detector will enter to the Quiescent mode.

3.4.3 Hold a can of aerosol simulating smoke to the sensing chamber of the detector and release a burst of smoke agent. The detector shall enter the Fire Alarm mode and send the relevant message via its alarm loop.

3.4.4 A more simplified functional test can be conducted by lighting the detector's LEDs or the LED of the connected remote indicator VUOS-31 with the laser beam of the remote test unit. The detector will go to the Fire Alarm conditions.

The distance between the remote test unit and the illuminated LED shall be at least 0.5 m.

3.4.5 Network controller's not registering the messages in question from the address point associated with the detector or abnormal operation / indication means that the detector is unhealthy and should be replaced.

3.4.6 When testing is completed, make sure that the detector is ready for normal operation. Reconnect executive outputs with fixed fire suppression equipment and notify the proper authorities that the system is back in normal operation.

Conduct all tests with equipment known to be in good conditions!

3.5 Technical Examination

Technical examination is not applicable for this equipment.

3.6 Preservation (Depreservation, Represervation)

Preservation is not applicable for this equipment.

4 Repair

Repair of a faulty detector is to be conducted by the manufacturer or in authorized repair centers. The detector shall be sent for repair in compliance with Company Standard QMS 8.5.3-2015, which can be found online at our website <https://bolid.ru/support/remont/>



Attention!

The equipment shall be submitted for repair being assembled and clean and along with all the parts listed in the documentation.

Claims are accepted only if a reclamation report describing the failure is applied to the submitted equipment.

A detector's failure resulted from consumer's not observing rules of mounting and operation is not a reason for claims and warranty repair.

Claims shall be submitted to the following address: NVP BOLID, #4 Pionerskaya Str., Korolyov, Moscow Region, 141070, Russia. Tel./fax: +7 (495) 775-71-55 (PBX).

E-mail: info@bolid.ru

In case of any issue related to use of the product, please contact the technical support: +7 (495) 775-71-55 or e-mail: support@bolid.ru.

5 Storage

Storage in a transport container is permitted at ambient temperatures -50°C through +50°C and relative humidity up to 95% at +35°C.

Storage in the consumer package is permitted only in heated premises at temperatures +5 through +40°C and relative humidity up to 80% at +20°C.

6 Transporting

The detectors can be transported in a transport container at ambient temperatures minus 50 through +50°C and relative humidity up to 95 % at +35°C.

7 Disposal

The detector should be disposed of considering that there are no toxic components in it.

The content of precious materials: doesn't require accountability for storage, retirement, and disposal (Clause 1.2 of GOST 2.608-78).

The content of non-ferrous metals: does not require accountability for retirement and further disposal.

8 Manufacturer Warranty

The manufacturer guarantees the detector meets with technical requirements stated in the manuals if the user follows the instructions for transportation, storage, installation, and usage.

The warranty period is 18 months since putting the product into operation but no more than 24 months from the manufacturer's date of production.

9 Certification Information

9.1. DIP-31 meets the requirements of the Technical Regulations of the Eurasian Economic Union 'On requirements for fire safety and firefighting means' (TR EAEU 043/2017) and is covered by the Certificate RU C-RU.ПБ68.B.00360/21.

9.2. DIP-31 meets the requirements of the Technical Regulations TR EAEU 037/2016 'On the restriction of the use of certain hazardous substances in electrical and electronic equipment' and is covered by Conformity Declaration EAЭC № RU Д-RU.PA01.B.21887/20.

9.3. DIP-31 meets the requirements of the Technical Regulations TR CU 020/2011 'Electromagnetic compatibility of technical equipment' and is covered by Conformity Declaration EAЭC № RU Д-RU.ME61.B.00019/18.

9.4. The production of DIP-31 is awarded with the Certificate of Conformity GOST R ISO 9001. The Certificate is available on the website <https://bolid.ru> in the section ABOUT.