

**ShPS-24 FIRE EQUIPMENT MOUNT BOXES
WITH BACKUP BATTERY POWER SUPPLIES**

ShPS-24

ShPS-24 mod.01

ShPS-24 mod.02

ShPS-24 mod.10

ShPS-24 mod.11

ShPS-24 mod.12

User's Manual

TABLE OF CONTENTS

1	Description and Operation	4
1.1	Purpose.....	4
1.2	Specifications.....	5
1.3	Scope of Delivery.....	7
1.4	Arrangement and Operation.....	7
1.5	Measuring Instruments, Tools, and Accessories.....	13
1.6	Marking.....	13
1.7	Packaging.....	13
2	Intended Use.....	13
2.1	Operating Restrictions	13
2.2	Preparing for Use	13
2.2.1	Safety Precautions.....	13
2.2.2	ShPS-24 Design	13
2.2.3	Mounting ShPS-24.....	13
2.2.4	Wiring ShPS-24	14
2.2.5	Programming ShPS-24.....	15
2.2.6	Usage.....	17
2.2.7	Performance Testing	17
2.2.8	Extreme Situation Actions	20
2.2.9	Troubleshooting	20
3	Maintenance	20
3.1	General.....	20
3.2	Safety Precautions.....	20
3.3	Maintenance Procedures	20
3.4	Operability Testing	21
3.5	Technical Examination	21
3.6	Preservation (Depreservation, Represervation)	21
4	Repair	21
5	Storage.....	21
6	Transporting	21
7	Disposal.....	21
8	Manufacturer Warranty	21
9	Certification Information.....	22
	Appendix A.....	23
	Appendix B	25
	Appendix C	26
	Appendix D.....	27
	Appendix E	28
	Appendix F.....	29
	Appendix G.....	30
	Appendix H.....	31

This User's Manual is meant for studying of principles of functioning and operation of ShPS-24, ShPS-24 mod.01, ShPS-24 mod.02, ShPS-24 mod.10, ShPS-24 mod.11, or ShPS-24 mod.12 Fire Equipment Mount Box with Battery Backed Power Supply (hereinafter referred to as ShPS-24).

ShPS-24 mod.01 differs from ShPS-24 by transparent window being in its door. ShPS-24 mod.02 differs from ShPS-24 by IP54 ingress protection rating.

ShPS-24 mod.11 differs from ShPS-24 mod.10 by transparent window being in its door; ShPS-24 mod.12 differs from ShPS-24 mod.10 by IP54 ingress protection rating.

ShPS-24 mod.10, ShPS-24 mod.11, ShPS-24 mod.12 differ from ShPS-24, ShPS-24 mod.01, ShPS-24 mod.02 by equipping with two separate RS-485 interface lines for connecting external devices (instead of a single line, see Clause 1.2.9).

Only the personnel who have studied this manual are allowed to operation activities. All activities on mounting, start-up, programming, and testing shall be performed in compliance with the requirements of the regulatory documentation in force at the place of operation.

Abbreviations:

ADC: Analog-to-Digital Converter

ShPS-24: ShPS-24, ShPS-24 mod.01, ShPS-24 mod.02, ShPS-24 mod.10, ShPS-24 mod.11, or ShPS-24 mod.12 Fire Equipment Mount Box with Battery Backed Power Supply;

BK-24: BK-24 or BK-24-RS485 (for ShPS-24 mod.10, ShPS-24 mod.11, ShPS-24 mod.12) Switching Unit;

ISS: Integrated Security System;

MIP-24: MIP-24 Power Supply Module.

1 Description and Operation

1.1 Purpose

1.1.1. ShPS-24 boxes are meant to provide power supply for groups of housed fire protection equipment and other equipment that require 24 V/DC.

1.1.2. A ShPS-24 box can accommodate the following Orion ISS devices: Signal-10, Signal-20P, S2000-4, S2000-KDL, S2000-KPB, S2000-SP1, S2000-PI, S2000-KDL-2I, Ruper rev.02, S2000-PGE, S2000-PGE rev.01, S2000-Ethernet, S2000-RPI and other devices mountable on a 35 mm top-hat DIN rail in accordance with GOST R IEC 60715-2003.

1.1.3. ShPS-24 mod.10, ShPS-24 mod.11, and ShPS-24 mod.12 are intended for operation with Sirius Fire Alarm Control Panel and C2000M Monitoring and Control Panel for Fire and Intrusion Alarm System and their modifications.

1.1.4. Every ShPS-24 mod.10, ShPS-24 mod.11, or ShPS-24 mod.12 features two separate RS-485 communication lines* for connecting with external fire protection equipment and other equipment outside the box. A single fault in one of the communication lines* does not affect operability of the other one. Fire protection equipment and other equipment that is inside the box are to be connected between each other as per their operating documentation.

1.1.5. ShPS-24 is designed for 24/7 continuous operation with intended output parameters, automatic monitoring and charging of sealed backup batteries. ShPS-24 provides disconnecting backup batteries from load circuits to avoid unacceptable discharge.

1.1.6. ShPS-24 provides visual and audible indication of the following: availability of mains power, high / low mains power voltage, backup battery charge, missed batteries, disconnection of low batteries, output short circuit / overcurrent, charger faults, output overvoltage, status of communications over the RS-485 interface bus.

1.1.7. ShPS-24 provides overvoltage and short-circuit protection for 24 V/DC outputs, with output voltage restoring automatically after having an output short-circuit fault repaired in case of being powered by mains and from batteries.

1.1.8. ShPS-24 provides short-circuit protection for battery connection terminals, with output voltage being still effective when working on mains power supply.

1.1.9. ShPS-24 provides measurement of mains voltage, output voltage, battery voltage, and output current (load current).

* See Clause 3.20 of the CII 484.1311500.2020 regulations

1.1.10. ShPS-24 provides transmitting measurements of voltage and current and actual device status to the network controller (S2000M panel, Sirius panel, or workstation with Orion Pro Suite) over the RS-485 interface.

1.1.11. ShPS-24 can issue fault messages to the remote output, which is the solid state relay output circuit with galvanic isolation.

1.1.12. ShPS-24 provides monitoring status of the batteries and battery-connection circuits (by comparing their internal resistance values with maximum threshold values).

1.1.13. ShPS-24 can supply power to additional power consumers with rated supply voltage 230 V, 50 / 60 Hz. ShPS-24 provides these additional consumers with short-circuit protection by means of a circuit breaker.

1.1.14. ShPS-24 shall be operated at places protected against atmospheric precipitations and mechanical damage. ShPS-24 is not designed for installations in locations where they can be exposed to explosion and flammable hazards.

1.1.15. ShPS-24 is classed as restorable and periodically serviced equipment.

1.2 Specifications

Table 1

No.	Parameter	Value
1.2.1.	Power Inputs	2
1.2.2.	Primary power supply: The mains utility power 230 V AC, 50 / 60 Hz, work range, V	150...253
1.2.3.	Backup power supply: Bolid series batteries AB 1217 (the type C or M)* or similar, 12 V, 17 Ah, pcs.	2
1.2.4.	Output voltage: while powered by	mains, V
		batteries, V
		27.2±0.6 27...19
1.2.5.	Rated / maximum total load current, A	2 / 2.2 **
1.2.6.	Outputs for powering devices consuming 24 V and installed within ShPS-24	7
1.2.7.	For ShPS-24, ShPS-24 mod.01, ShPS-24 mod.02: Maximum current per a single output 24 V/dc, A	0.4
	For ShPS-24 mod.10, ShPS-24 mod.11, ShPS-24 mod.12: Maximum current per a single output 24 V/dc XT1...XT6, A	0.4
	Maximum current per the XP3 output 24 V/dc, A	0.6
1.2.8.	Outputs for connecting RS-485 interface lines installed within ShPS-24	7
1.2.9.	For ShPS-24, ShPS-24 mod.01, ShPS-24 mod.02: RS-485 port for connecting external devices over the RS-485 interface	1
	For ShPS-24 mod.10, ShPS-24 mod.11, ShPS-24 mod.12: Separated RS-485 ports for connecting external devices over the RS-485 interface	2
1.2.10.	Length of RS-485 interface bus to every device inside ShPS-24 mod.10, ShPS-24 mod.11, ShPS-24 mod.12, m, max	10
1.2.11.	For ShPS-24 mod.10, ShPS-24 mod.11, ShPS-24 mod.12: the length of every separate RS-485 interface line at 9600 bit/s, m, max	3000
1.2.12.	Capacity of non-volatile event log	95
1.2.13.	Maximum power consumed from the mains, V·A / W	120 / 65
1.2.14.	Maximum current consumed from the mains, A	0.8
1.2.15.	Current consumed from the batteries by the ShPS-24 itself: For ShPS-24, ShPS-24 mod.01, ShPS-24 mod.02, mA, max	40
	For ShPS-24 mod.10, ShPS-24 mod.11, ShPS-24 mod.12, mA, max	120

No.	Parameter	Value
1.2.16.	Ripples of the output voltage (peak-to-peak) at rated load current (VR1 class as per GOST R 51179), mV, max	100
1.2.17.	Low-battery shutdown voltage, V	20.4±0.6
1.2.18.	The ShPS-24 backup time when started with full-charged batteries at 2 A load current and temperature of 298 K (+25 °C), hours, at least	8
1.2.19.	Time to charge fully discharged batteries, hours, max Maximum charging rate for each battery, A	36 0.7
1.2.20.	Maximum current available for additional consumers of mains power 230 V, 50 / 60 Hz, A	10
1.2.21.	Electric shock protection class as per GOST 12.2.007.0-75	I
1.2.22.	Enclosure protection degree as per GOST 14254-2015 • ShPS-24, ShPS-24 mod.01, ShPS-24 mod.10, ShPS-24 mod.11 • ShPS-24 mod.02, ShPS-24 mod.12	IP41 IP54
1.2.23.	Vibration exposure: - Frequency range, Hz - Max acceleration, g	1-35 0.5
1.2.24.	Environmental category as per OST 25 1099-83	O3
1.2.25.	Operating temperature range, °C	Minus 10 through +40
1.2.26.	Relative air humidity at +40°C, %, max	93
1.2.27.	ShPS-24 weight without batteries / with batteries, kg	15 / 27
1.2.28.	Overall dimensions, mm	650 × 500 × 220
1.2.29.	Non-stop operation	Round-the-clock
1.2.30.	MTBF, h	40,000
1.2.31.	Survival probability over a period of 1000 hours	0.975
1.2.32.	Expected service life of ShPS-24, years	10

* The letters C and M define the battery service life as 12 and 15 years respectively.

** The maximum load current is 2.2 A (for short-duration periods of up to 10 minutes at intervals of at least one hour provided that the mains power is available and batteries are connected). When the output current exceeds 2.2 A, ShPS-24 turns off the charger. When the output current is over 2.5 A, ShPS-24 disables the output voltage.

1.2.33. ShPS-24 provides monitoring mains voltage, output voltage, and battery voltage with automatic sending over the RS-485 interface messages about presence of relevant voltages / faults, battery discharge, bad battery health and battery disablement, and tampering.

1.2.34. The built-in PSU of ShPS-24 is ready to operate after 6 seconds upon powering up.

1.2.35. ShPS-24 features a Remote Fault Output, which is a solid state relay with the following parameters: maximum switched voltage / current is 80 V / 50 mA; maximum resistance of closed relay circuit is 50 Ohm; maximum open circuit leakage current at 80 V is 1 uA.

1.2.36. ShPS-24 supports event sharing over RS-485 (see 1.4.2-g) and executing commands instructed over RS-485.

1.2.37. ShPS-24 boxes provide programming parameters in their non-volatile memory (see 2.2.5.5).

1.2.38. ShPS-24 provides measuring and sending of measured values in response to a request of the network controller on:

- 1) Mains voltage in the range of 150 through 255 V/AC;
- 2) Battery voltage in the range of 16 through 29 V/DC;
- 3) Output voltage in the range of 16 through 29 V/DC;
- 4) Output current (load current) in the range of 0.1 through 2.5 A.

Note: The engineers sought to achieve measurements of high precision; however the measured values are of an assessment nature with absolute and relative errors of measured values being not standardized. To carry out precise measurement, certified instruments shall be used.

1.2.39. ShPS-24 design provides protection against unauthorized access inside the box by means of the key lockable door. There are no control elements outside the ShPS-24 box.

1.2.40. ShPS-24 provides tamper monitoring by means of a tamper switch which contacts are closed when the box door is closed.

1.2.41. In terms of immunity to electromagnetic interference, ShPS-24 meets the requirements of Test Severity Level III with performance criteria A as per the relevant standards listed in Appendix 'B' to GOST R 53325-2012.

1.2.42. ShPS-24 boxes pass the industrial interference standards prescribed for Class 'B' equipment as per GOST R 30805.22.

1.2.43. The design of the ShPS-24 meets the requirements on fire and electric safety including emergency operation in accordance with GOST 12.1.004-91, GOST 12.2.007.0-75, GOST R 50571.3.

1.2.44. ShPS-24 mod.01 and ShPS-24 mod.11 boxes feature transparent windows on their doors, the doors' sizes being specified in Appendix G.

1.2.45. Insulation strength of live parts of ShPS-24 is not less than 2,000V (50Hz) between circuits linked to 230 V AC and the enclosure as well as between circuits linked to 230 V AC and any circuits not linked to 230 V AC.

1.2.46. For ShPS-24 mod.10, ShPS-24 mod.11, and ShPS-24 mod.12 insulation strength of separate interface lines and other circuits is at least 500 V, 50 Hz.

1.2.47. Electrical insulation resistance between the circuits mentioned in the paras 1.2.45 and 1.2.46 is at least 20 mega ohms (in normal conditions as defined in Clause 5.14.6 of GOST 52931).

1.2.48. In case of normal operation and in case of faulty conditions neither of the ShPS-24 components runs hot over admissible temperature values stated in GOST R IEC 60065.

1.3 Scope of Delivery

Table 2 presents the delivery scope for ShPS-24.

Table 2

Item	Q-ty, pcs.
ShPS-24 ShPS-24 mod.01 ShPS-24 mod.02 ShPS-24 mod.10 ShPS-24 mod.11 ShPS-24 mod.12	1
Accessory Kit:	
Fastener kit: (eye bracket, bolt, nut, screw, wall plug)	4
Rubber cable gland: ShPS-24; ShPS-24 mod.01; ShPS-24 mod.10; ShPS-24 mod.11	6
ShPS-24 mod.02; ShPS-24 mod.12	4
For ShPS-24 mod.10, ShPS-24 mod.11, ShPS-24 mod.12: Jumper MJ-0-6 (2.54 × 6 mm)	2
Key	2
Packaging	1
Documentation	
ShPS-24, ShPS-24 mod.01, ShPS-24 mod.02, ShPS-24 mod.10, ShPS-24 mod.11, ShPS-24 mod.12 Operations Manual	1

Note: No battery is included in the standard delivery!

1.4 Arrangement and Operation

1.4.1. A ShPS-24 is assembled within a metal enclosure. The enclosure consists of a cabinet and a key lockable door. On the outer surface of the door there are light indicators to indicate the ShPS-24 conditions. The cabinet houses the MIP-24 power supply module, the BK-24 switch unit for connections, and circuit breakers for connecting the mains 230 V and connecting power consumers to the mains 230 V. In the bottom part of the cabinet there is a place for installing batteries.

1.4.2. Operation of the ShPS-24 Power Supply Module (MIP-24).

a) Mains power having turned on, ShPS-24 checks availability of the batteries and RS-485 communications. If the batteries are charged (100% against ShPS-24's charge scale), the BATTERY

indicator is on. If the batteries are in the discharged condition, ShPS-24 starts charging them to the required level, with the BATTERY indicator turning off for a short time once per every five seconds. If one of the batteries is not connected (or its output voltage is lower than 7 V), the BATTERY indicator starts flashing once per second. If the batteries are in poor conditions (subject to replacement), the buzzer beeps five times, and the BATTERY and FAULT indicators start flashing with 2-Hz frequency. If the charger fails (stays failed during 15 seconds), ShPS-24 issues the Charger Fault event and indicates the fault status according to Table 3.

During operation ShPS-24 periodically checks:

- Input / output voltage;
- Availability of the batteries (at least every minute);
- Battery health (at least every 15 minutes);
- Charger functionality (at least every 15 minutes).

b) When the mains voltage fails, the batteries start powering the load; the buzzer starts beeping to report on discharging; the POWER indicator is off; the 24V indication is on; the ShPS-24 transmits the Mains Fault events when a delay time expires (see parameter 2 in Table 5).

c) When the battery voltage drops to 22 V, the buzzer starts pulsing 10-15 times more frequently. ShPS-24 issues the Battery Low event. Urgent measures shall be taken to recover the main power.

d) When batteries' voltage drops to 20 V, they are switched off from the load to avoid being discharged heavily. The 24V indicator is off; the buzzer generates steady (continuous) beep during the further two hours. ShPS-24 issues the Output Voltage Fault event. After two hours, ShPS-24 goes into the mode of minimal consumption; the RS-485 transceiver is off; both the buzzer and the FAULT indicator pulse once every 10 seconds.

WARNING! If the mains power is expected to be disabled for more than 7 days, the batteries should be disconnected from the MIP-24 to avoid their unacceptable discharging.

The buzzer can be muted (see 2.2.5.3). To unmute the buzzer, please repeat the sequence of tamper button presses.

e) When the mains power failed and the battery level is still higher than 80% of its rated capacity, ShPS-24 starts measuring the actual capacity of the installed batteries. When the batteries are lower than 22 V, ShPS-24 estimates the battery capacity, backup time, and approximate time for measuring the battery capacity. When the battery level is lower than 80% of rated capacity, the capacity measurement process does not start. If for the ShPS-24 box no measurement of battery capacity was carried out during operation and the ShPS-24 box is requested for backup operation time and time to measure the capacity, it will calculate these details on the assumption of installed batteries of 17 Ah capacities and current values of charge scale value, temperature, and output current.

f) If an unacceptable output overload or short-circuit fault occurs, ShPS-24 goes into the mode of short output pulsing every 10 seconds until the fault is repaired. The FAULT LED starts pulsing every 0.5 seconds; the buzzer starts beeping intermittently. After the output overload or short-circuit fault is repaired, ShPS-24 recovers automatically within 15 seconds.

WARNING! When overcurrent exceeds 2.2 A but it is still less than 2.5 A, the MIP-24 disables the battery charger, output voltage being on. As this take place, the ShPS-24 indication performs as shown in Table 3, para 5.

Light indicators and buzzer performance depending on various conditions are presented in Table 3. If some light indicator performance differs from that described in Table 3 and Table 7 or some deviation from normal operation of the ShPS-24 is detected, please contact the Bolid technical support (please refer to 4.5 for contact information).

Following is the list of notations used in Table 3:

- “+”: Switched on, “–”: Switched off;
- “+/- 1 Hz”: Switches on and off alternately every second;
- “ON 2 s”: Switches on for a short time every 2 seconds;
- “OFF 3 s”: Switches off for a short time every 3 seconds;
- “ON”: Switches on for a short time.

Table 3

Current conditions	LED Indicators					Buzzer
	POWER	BATTERY	FAULT	RS-485	24 V	
	<i>green</i>	<i>green</i>	<i>amber</i>	<i>green</i>	<i>green</i>	
1. Powering on with no battery connected	+	+/- 1 Hz	—	+ ¹	+	ON 0.4 s 3 times
2. Mains voltage is normal; batteries are in discharged condition	+	OFF 5 s	—	+ ¹	+	—
3. Mains voltage is normal; batteries are in charged condition	+	+	—	+ ¹	+	—
4. Output overcurrent (above 2.5 A) / short circuit (batteries are available)	+	+	+/- 2 Hz	+ ¹	ON 10 s	ON 0.8 s
5. Output overcurrent (between 2.2 A and 2.5 A) when the battery are available	+	+	+/- 2 Hz	+ ¹	+	ON 0.8 s
6. Mains voltage failed; batteries voltage is higher than 22 V	—	+	—	+ ¹	+	ON 5 s
7. Mains voltage failed; batteries voltage is below 22 V	—	+	—	+ ¹	+	ON 0.4 s
8. Mains voltage failed; batteries voltage is lower than 20.4 V (during first two hours)	—	+/- 1 Hz	—	+ ¹	—	+
9. Mains power failed; battery voltage is lower than 20.4 V (after two hours)	—	—	ON 10 s	—	—	ON 10 s
10. Mains voltage is lower than 150 V or higher than 260 V	+/- 1 Hz	+	—	+ ¹	+	ON 0.8 s
11. Batteries are in poor condition (replacement required)	+	+/- 1 Hz	+/- 1 Hz	+ ¹	+	5 beeps
12. Charger failure	+	+/- 4 Hz	+/- 4 Hz	+ ¹	+	ON 0.8 s
13. ShPS-24's output overvoltage	+/- 1 Hz	+/- 1 Hz	+/- 1 Hz	+/- 1 Hz	+ ²	ON 0.8 s

¹ When communications over RS-485 is in the normal condition. If communications fails, it is turned off. If initially normal communications over RS-485 fail, the RS-485 LED starts 1-Hz flashing after 30 seconds of failure occurrence.

² Upon output voltage's exceeding 31 V, provided that the batteries are available ShPS-24 turns off the voltage converter and proceeds to operating from the batteries. In case of absent batteries the voltage converter keeps operating.

g) ShPS-24 can transmit the following messages over RS-485:

- Device Reboot (when ShPS-24 has been powered on);
- Mains Failed (the mains supply voltage is lower than 150 V or higher 250 V);
- Mains Restored (the mains supply voltage recovered to the range of 150V to 250V);
- Overload (the ShPS-24's output current exceeds 2.2 A);
- Load Restored (the ShPS-24's output current has been normal (less than 2.2 A));
- Charger Failed (the charger failed to provide proper voltage and current to charge the batteries);
- Charger Restored (charger provides proper voltage and current values to charge the batteries);
- Power Failed (the mains power being applied to the box, ShPS-24 does not provide functions according to 1.2.4);
- Power Restored (the mains power being applied to the box, ShPS-24 provides functions according to 1.2.4);
- Battery Fault (voltage of any of the batteries is lower than 7V or batteries are not connected);
- Battery Test Error (battery internal resistance is higher than a critical threshold, and the batteries have to be replaced or repaired, see item 10 in Table 3; or the battery charge level being 100%, the difference between the individual battery voltage values exceeds 2 V);
- Battery Low (battery voltage is lower than 22 V, mains power being not available);
- Service Required (battery lifetime has expired; the batteries are subject to replacement);

- Battery Restored (voltage produced by batteries exceeds 20 V; the batteries can be charged);
- Tamper Alarm (the ShPS-24 enclosure has been opened);
- Tamper Restored (the ShPS-24 enclosure has been closed);
- Output Voltage Off (ShPS-24 has turned off the output voltage due to the mains failed and batteries discharged);
- Output Voltage On (ShPS-24 has turned on the output voltage upon the mains power is restored after batteries discharging).

If in the moment of message generation there is no connection with a network controller over RS-485, the message is stored in non-volatile memory of ShPS-24, and it will be transmitted as soon as the connection is recovered. The time stamp of message will get the actual time of the event occurrence.

The buffer (event log) in the nonvolatile memory of ShPS-24 can store up to 95 events.

h) To request the status of ShPS-24 using the S2000M panel (see S2000M User’s Guide):

CODE: _	Enter a passcode
◆ 5 VIEW INPUT STATUS	Select the View Input Status using the ▶ ◀ buttons and press ↵, or press 5 for quick navigation
◆ 51 INPUT STATUS	Select the Input Status item using the ▶ ◀ buttons and press ↵ or press 1 for quick navigation
ADDRESS: _	Enter the device address (1 to 127) or select it from the menu using the ▶ ◀ buttons, and then press ↵
INPUT #: _	Enter the required input number (see below) or select it using the ▶ ◀ buttons, and then press ↵

For ShPS-24, status of the following can be requested on the relevant inputs:

Input #0: Tamper switch	Input #1: Output voltage
Input #2: Output current	Input #3: Battery voltage
Input #4: Charger	Input #5: Mains voltage

i) To view the resulted voltage and current measurements (see S2000M Users’ Guide):

CODE: _	Enter a passcode
◆ 5 VIEW INPUT STATUS	Select the View Input Status using the ▶ ◀ buttons and press ↵, or press 5 for quick navigation
◆ 52 INPUT ADC	Select the Input ADC item using the ▶ ◀ buttons and click ↵, or click 2 for quick navigation
ADDRESS: _	Enter the device address (1 to 127) or select it from the menu using the ▶ ◀ buttons and press ↵
INPUT #: _	Enter the required input number or select it from the menu using the ▶ ◀ buttons and press ↵

The requested data are presented in the form of text and specific ADC values:

Input	Information on the S2000M display Use the ◀ ▶ buttons to browse measurements
# 0	<ul style="list-style-type: none"> – ТЕМПЕРАТУРА +25°C – Трезерв = 07 ч 50 мин (Depends on the battery capacity, output current, and battery temperature) or Изм. ждите... (The MIP-24 is calculating the value, please wait for about a minute) or АКБ ОТКЛЮЧЕН (No batteries are connected to the MIP) – Тгеста = 07 ч 00 мин (Depends on the battery capacity, output current, and battery temperature) or Заряд АКБ <80% (Battery charge is less than 80%; no capacity can be measured) or Изм. ждите... (The MIP-24 is calculating the value, please wait for about a minute) or АКБ ОТКЛЮЧЕН (No batteries are connected to the MIP) – Ёмкость 17,00 Ач (The last measured capacity) or Ёмкость не изм. (No battery capacity was measured) or АКБ ОТКЛЮЧЕН (No batteries are connected to the MIP) – Тнар_ост = 43800 ч (5 years)
# 1	– Uout = 16...29V
# 2	– Iout = 0,1...2,5 A
# 3	<ul style="list-style-type: none"> – Uакк = 16...29 V or Uакк = 00,00V (No battery is connected to the MIP) – Трезерв = 03 ч 50 мин (Depends on the battery capacity, output current, and battery temperature) or Изм. ждите... (The MIP-24 is calculating the value, please wait for about a minute) or АКБ ОТКЛЮЧЕН (No batteries are connected to the MIP) – Тгеста = 03 ч 00 мин (Depends on the battery capacity, output current, and battery temperature) or Заряд АКБ <80% (Battery charge is less than 80%; no capacity can be measured) or Изм. ждите... (The MIP-24 is calculating the value, please wait for about a minute) or АКБ ОТКЛЮЧЕН (No batteries are connected to the MIP) – Ёмкость 17,00 Ач (The last measured capacity) or Ёмкость не изм. (No battery capacity was measured) or АКБ ОТКЛЮЧЕН (No batteries are connected to the MIP) – Тнар_ост = 43800 ч (5 years)
# 4	<ul style="list-style-type: none"> – Заряд АБ 100 % (Charger in norm) or Авария ЗУ (Charger failed) or ЗУ НОРМА (No batteries are connected to the MIP; the charger operates properly)
# 5	– Усети = 150...255 V

Note: * The 230 V mains voltage measured by ShPS-24 can differ if compared to values measured with a RMS voltmeter. This may be due to distortion of mains power y-voltage, etc. ShPS-24 can adjust the main voltage measurements with a 1 V increment (in ± 20 V range). To adjust the measurements, please run the UProg utility, select the MIP-24-2A RS with the corresponding network address, and select the values to be adjusted in the appeared dialog box. ShPS-24 will adjust the selected values to the values of mains voltmeter after saving configuration and reset.

1.4.3 Operation of ShPS-24 mod.10, ShPS-24 mod.11, ShPS-24 mod.12 under Sirius Panel

To request conditions as well as to view various values measured by ShPS-24 using Sirius Fire Alarm Control Panel, do the following (as stated in the Sirius ver.1.00 user's manual):

a) Connect ShPS-24 to the LINE1 and / or LINE2 terminals of the separate RS-485 (UNITS) interface of the Sirius panel (refer to 7.2.5 of Sirius User's Guide).

b) Define the Sirius database through the Configuration tab of the web interface:

- Add the device MIP-24 into the Sirius database and include it to any zone; give a name for the device if necessary;

- Add inputs No.1...No.5 into the Sirius database with input types set to Auxiliary (by default); all the inputs shall be added to the same zone where the MIP-24 is included. Edit the input names if necessary;
- c) Authorize your access to the Sirius panel by entering the User PIN 77777.
- d) Press the ZONE button to enter the mode of displaying of all zones and zone groups of the system.
- e) Using arrow buttons, select the zone the MIP-24 with all its inputs is included into, and then press Enter to view the zone content.
- f) Using arrow buttons, select the MIP-24 input (or the device itself) which status and measured values are required to be requested and press Enter to view the received data.
- g) In the Input Information mode, with arrow buttons you can switch between windows indicating information on configuration parameters of the input, input multistate (along with event origin times), and measured ADC values on the input:

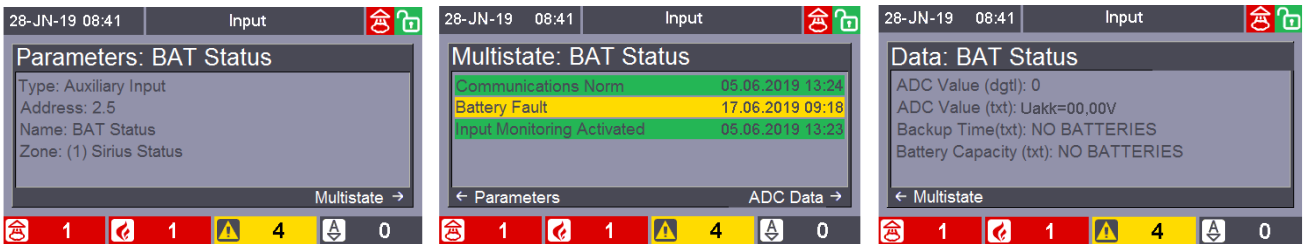

1.4.4. Operation of ShPS-24 mod.10, ShPS-24 mod.11, ShPS-24 mod.12 under S2000M Rev.02 Control Panel

1.4.4.1. For small facilities with an addressable fire alarm system where it is no need to integrate several control panels into a network connected to Orion Pro software, it is reasonable to use an S2000M rev.02 control panel. To operate an S2000M rev.02 with RS-485 interface redundancy protection, both interfaces should be connected to separate interfaces of the BK-24-RS485. For more detail information, please refer to S2000M Rev.02 User’s Manual, which can be found at www.bolid.ru in the section PRODUCTS.

1.4.5. Updating Firmware

1.4.5.1. ShPS-24 boxes support updating their firmware in field over the RS-485 interface by means of the Orion_prog utility (“Firmware Update”). The last version of this program is available online at the address of <http://bolid.ru>.



WARNING!
During updating firmware MIP-24 disables output voltage

1.4.5.2. For ShPS-24 mod.10, ShPS-24 mod.11, ShPS-24 mod.12 BK-24-RS485 supports updating firmware versions in field over the RS-485 interface by means of the Orion_prog utility (“Firmware Update”). The last version of this program is available online at the address of <http://bolid.ru>. To switch the BK-24-RS485 to the programming mode, please close the jumper circuit XP5 (“PROG”) on the board of the BK-24-RS485. The programming mode is indicated by two board LEDs’ blinking once per second. Only one of the separate RS-485 interfaces is used for updating.



WARNING!
Upon entering the programming mode, BK-24-RS485 occupies the address 127. So, for correct operation this address should be vacant

1.5 Measuring Instruments, Tools, and Accessories

While mounting, commissioning, and maintaining ShPS-24, please use the instruments, tools, and accessories shown in Table 4.

Table 4

Instrument	Specifications
Digital multimeter	AC/DC voltage up to 500 V, AC/DC current up to 10 A, resistance up to 20M Ohm
Flat head insulated screwdriver	SL2.5 x 75 mm
Cross slot insulated screwdriver	PH1 x 75 mm
Side-cutting pliers	160 mm
Pliers	160 mm

1.6 Marking

Every ShPS-24 box has a marking applied to its enclosure.

The marking contains the name of the device, its decimal number, factory number, the year and quarter of production, and conformity marks.

1.7 Packaging

A ShPS-24 box along with accessory kit and operation documentation is packaged in a separate cardboard box.

2 Intended Use

2.1 Operating Restrictions

The design of ShPS-24 doesn't provide its operation in aggressive and / or dusty environments as well as in explosion and fire hazardous premises.

Correct performance of ShPS-24 cannot be guaranteed if electromagnetic environment does not meet the requirements defined in Section 1.2 of this manual.

2.2 Preparing for Use

2.2.1 Safety Precautions

2.2.1.1. The ShPS-24 design meets the requirements of electric and fire safety including emergency operation in accordance with Russian standards GOST 12.2.007.0-75 and GOST 12.1.004-91.

2.2.1.2. The hazardous items of ShPS-24 are current-carrying circuits connected to 230V AC.

2.2.1.3. Installation, mounting, and maintenance shall not be carried out until the equipment mount box is disconnected from the mains power.

2.2.1.4. Installation and maintenance shall be carried out by professionals qualified for Accident Prevention of Class III or higher.

2.2.1.5. Precautions:

It is not allowed using a ShPS-24 box without grounding

- a) Check regularly the ShPS-24's grounding.
- b) Do not open the ShPS-24 enclosure unless it is disconnected from power supply.
- c) Do not remove the MIP-24 cover.

2.2.1.6. Before the use, ShPS-24 shall be grounded to avoid electrical shock. Protection Class is I as per GOST IEC 60950-2002.

2.2.2 ShPS-24 Design

Please refer to Appendices E, F, and G for ShPS-24 appearance and overall / mounting dimensions.

Every ShPS-24, ShPS-24 mod.01, ShPS-24 mod.10, or ShPS-24 mod.11 is equipped with two Ø30 mm cable entry points on the bottom of its enclosure and with four Ø30 mm cable entry points on the top of its enclosure. The distances between cable entries are 300 mm on the bottom and 100 mm on the top of the box enclosure.

Every ShPS-24 mod.02 or ShPS-24 mod.12 is equipped with four Ø50 mm cable entry points on the bottom of the box enclosure, with the distance between entries being equal to 100 mm.

2.2.3 Mounting ShPS-24

Installation, mounting, and maintenance shall not be carried out until the equipment mount box is disconnected from the mains power. Installation and maintenance shall be carried out by professionals qualified for Accident Prevention of Class III or higher.

2.2.3.1. Mounting Equipment Inside Box

The box is used to house and power housed Orion ISS equipment or other devices meant for the DIN-rail installation. The Appendices B and C show options of how the equipment can be placed in the box.

Rails can be moved to a required height for the equipment to be located conveniently. Unused rails can be removed.

The equipment also can be mounted on the box door (except for ShPS-24 mod.01 and ShPS-24 mod.11). For this purpose, install additional rails using special pins (Appendix D). Additional rails are included in the MK-1 ShPS mount kit (supplied separately).

Examples of equipment layout can be downloaded at

http://bolid.ru/files/373/566/Primery_raspolzheniya_oborudovaniya.zip.

If necessary, the equipment can be installed on the rear wall of the ShPS-24 box; please remove unused rails for this purpose. Also, please remove transporting tie-wraps from the BK-24 and MIP-24 prior to operating ShPS-24.

Devices are mounted in the box and connected to the BK-24 terminals by users themselves:

- Terminals marked as “0” and “+U” are used to connect power supply circuits, but care must be taken to observe the proper polarity.
- For ShPS-24, ShPS-24 mod.01, ShPS-24 mod.02 terminals marked as “A1 B1”, “A2 B2”... “A7 B7” are used to connect the RS-485 circuits. External RS-485 circuits must be connected to “A8 B8” terminals.
- For ShPS-24 mod.10, ShPS-24 mod.11, ShPS-24 mod.12:
 - Terminals marked as “A B” are used to connect circuits of the internal RS-485 interface bus of the box where the BK-24 and devices are installed. The length of the internal RS-485 interface line shall not exceed 10 m for every device.
 - Terminals marked as “ISO Port #1” (the first separate RS-485 interface) and “ISO Port #2” (the second separate RS-485 interface) are used for connecting to external RS-485 interface circuits.

If necessary, the user can use the XT2 earthing bus to ground additional devices powered from 230 V /AC. The 230 V power circuits are protected by the common QF1 circuit breaker.

Upon erecting wires and cables passed through within ShPS-24, ShPS-24 mod.01, ShPS-24 mod.10, ShPS-24 mod.11 via upper cable glands, use a sealant (gasket maker) to seal inputs to provide IP41 enclosure protection degree. For this purpose, white organosilicone one-part sealant “BFO-1” is advised.

2.2.3.2. Installing the Box

Installation and connection of the boxes shall be provided in accordance with design documents developed as specified in effective regulatory documents and approved in the order as intended.

ShPS-24 can be installed on the walls and other structures of protected premises to avoid exposure to the atmospheric precipitation and mechanical damage.

Mount the eye brackets on the box using fasteners from the mounting kit provided. Attach the ShPS-24 on the wall at an easily accessible location. Overall and mounting dimensions can be found in Appendix E.

2.2.4 Wiring the ShPS-24

WARNING!



When connecting external 230 V mains supply voltage to the XT1 terminal block, care must be taken to observe the correct connection of the Line and Neutral wires. Make the connections in accordance with Appendix A. The connection diagram is also located on the inner side of the ShPS-24 door

Install the batteries.

In accordance with the wiring diagram (Appendix A):

- a) Set the circuit breakers QF1 and QF2 to the OFF position;
- b) **Ground the ShPS-24** by coupling the **XT1.3:2 “ \perp ”** input contact of the terminal block **XT1** with the ground circuit;
- c) Connect the interface bus and wires to be connected to devices positioned within the box to the relevant box terminals;

d) Connect power wires to the ShPS-24 inlet terminal (**L line shall be connected to XT1.1:2, see Appendix A**);

e) Mount batteries and connect them to terminals observing the polarity (the red wire shall be connected to the “+” lead of the first battery; a blue wire shall be connected to lead “-” of the second battery; one end of the white wire shall be connected to the “-” lead of the first battery, the other end of the wire shall be connected to “+” lead of the second battery).

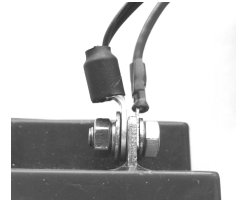

Figure 1

Connect O-shape terminal of the thermal sensor to the battery lead as shown in Figure 1, according to Appendix A.

f) Turn on the QF1 and QF2 circuit breakers.

Note: Rated load current is 2 A. The power supply may operate a short period under 2.2 A (see 1.2.5) in case of activation of sound alarm devices, fire-fighting systems, actuating devices, etc.

Warning! In case of long operation at overload, the battery charging process is terminated, and the battery starts discharging even if the mains voltage is available. If the total load current exceeds 2.5 A, the power supply unit turns OFF output voltage and the equipment IS LEFT WITHOUT THE POWER.

Recommended cross sections of wires connected to the ShPS-24 box are as follows:

- To 230V mains power (to XT1 terminal): 1.5 to 2.5 mm² for multi stranded wires or 1 to 2 mm² for solid wires;
- To RS-485 line (the BK-24 unit): 0.12 to 2 mm² for multi stranded wires or 0.4 to 1 mm² for solid wires;
- To connect loads (the BK-24 unit): 0.5 to 2 mm² for multi stranded wires or 1 to 2 mm² for solid wires with taking into account voltage drops at maximum load current (minimal permitted voltage when loaded).

When installation is completed, run the test of system operations in the Fire Alarm conditions during one hour to check whether the ShPS-24 is capable to provide functionality of the installed equipment as specified in 1.2.17. The batteries shall be fully charged before the test (indicated by steady light of the BATTERY LED).

2.2.5 Programming the ShPS-24

2.2.5.1. Change the network address of the ShPS-24 box. The new address shall be unique and different from all the addresses of devices connected to the same RS-485 line where this ShPS-24 is connected (the default address is 127).

2.2.5.2. If needed, change the rest configuration parameters according to your intended use of the ShPS-24 (see Table 5).

To change the ShPS-24 configuration parameters, please use an IBM-compatible computer with the **UProg** application installed. To connect the ShPS-24 to a PC COM port, an interface converter shall be used such as RS-232/RS-485 PI-GR, S2000-PI, or S2000M panel of version 1.20+ set as interface converter. Appendix H shows the application window.

The **UProg** utility can be downloaded at <http://bolid.ru>.

ShPS-24 provides protection against unauthorized configuring and using an alternative protocol for communicating data over RS-485. These features imply using access passwords. If these passwords are changed and lost, you can reset configuration to restore full access to the box. Resetting configuration is expected to be performed only in such emergency cases.

To reset all the configuration parameters to the factory values, turn off the ShPS-24 power and open the box door. Then apply power to the box again and within 30 seconds close the tamper switch three times for a short time, then three times for a long time, and finally three times for a short time again (. . . - - - . . .). A short time shall last 0.5 s max, while a long time means at least 1.5 s. Pauses between presses shall be 0.5 s max. If the combination of presses has succeeded, the same combination is “doubled” by the buzzer and RS-485 LED, with the Configuration Reset event being generated and configuration parameters being assigned to their default values.

2.2.5.3. The ShPS-24 door being open, the tamper switch can be used to:

- **Mute the buzzer** by three short and one long tamper button presses (● ● ● —);

Note: Holding the button down for 1.5 to 3 sec is long pressing (—). Holding the button down for 0.1 to 0.5 sec is short pressing (●). Pauses between presses shall not be shorter than 0.1 sec but no longer than 1sec.

- **Reset network address** (to set default address 127): (— — — ●);
- **Reset battery life counter and measured capacity** (when battery replaced): (● ● ● — —).

2.2.5.4. If the network controller is powered from another power supply, the circuits “0 V” of the ShPS-24, ShPS-24 mod.01, ShPS-24 mod.02 box and network controller shall be connected as a single circuit.

2.2.5.5. The programmable parameters are described in Table 5 and Table 6 (see Appendix H). The parameters are stored in the nonvolatile memory.

2.2.5.6. Unless ShPS-24, ShPS-24 mod.01, ShPS-24 mod.02 box is the first or the last device in the RS-485 interface bus then open the XP1 jumper located on the BK-24 board close to the XT1 terminal block (which is intended for connecting the devices) – see Appendix A.

2.2.5.7. If ShPS-24 mod.10, ShPS-24 mod.11, ShPS-24 mod.12 box is the first or the last device in the RS-485 interface bus then loosen the side limiter for connecting the end-of-line resistors and remove the cover from the BK-24 enclosure. On the BK-24 board, near the terminal block for connecting the separate RS-485 interface No.2 please find male-type connectors XP10 and XP11. Closing the connector XP10 with the jumper provided connects the end-of-line resistor to the separate RS-485 interface line No.1. Closing the connector XP11 with the jumper provided connects the end-of-line resistor to the separate RS-485 interface line No.2.

BK-24 RS-485 with Open Cover

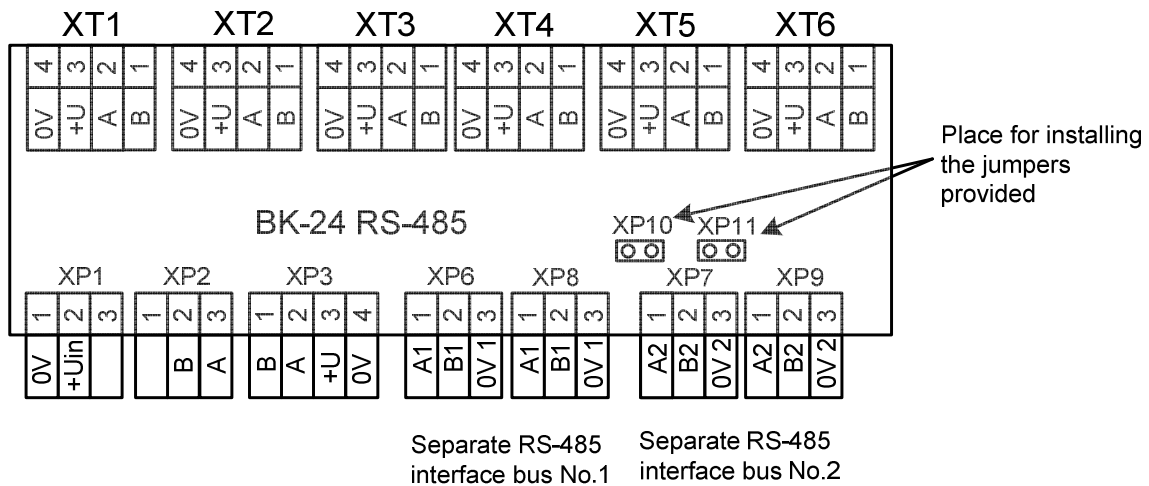

Figure 2

Table 5

Parameter	Description	Range	Factory Value
1 Network address	Device address in the RS-485 network	1...127	127
2 Delay for the Mains Failed event	Delay time before transmitting the Mains Fault event via the RS-485 interface	4...255 s	4 s
3 Delay for the Mains Restored event	Delay time before transmitting the Mains Restored event via the RS-485 interface	4...255 s	4 s
4 Battery life counter	Time set for the battery lifetime counter. When this time expires, ShPS-24 issues Service Required messages	1...15 years	10 years
5 Interval for repeating a Service Required message	Interval time for reissuing Service Required messages resulted due to expired battery lifetime as set for the counter	1...255 h*	255 h
6 Adjustment of mains power voltmeter	Increases or decreases voltage values in respect to mains voltmeter measurements	± 20 V	0 V

Parameter	Description	Range	Factory Value
7 Disablement of Battery Test Error messages	Disables the Battery Error messages for the BAT1 battery Disables the Battery Error message for the battery BAT2	On / Off On / Off	Events Enabled
8 Disablement of No Battery indication	Disables indication of missed BAT1 Disables indication of missed BAT2	On / Off On / Off	Indication Enabled

* If "0" is set for this parameter, the message is issued one time only.

Programmable Parameters for the Solid State Relay: **Table 6**

Parameter	Description	Value	Factory Value
1 Control Program	Relay control program running right after powering on the ShPS-24 (or reboot)	Turn On Turn Off Turn On for a Time Turn Off for a Time	Turn Off
2 Relay Activation Time	Time for the relay to be turned on / off for the commands Turn On for a Time and Turn Off for a Time	0... 8191.875 s	8191.875 s
3 Relay Control Option	Selection of monitored parameters to activate the relay control program	1. All parameters but for communications 2. Communications fault 3. Output current overload 4. ShPS-24 failure (charger, Uout) 5. Battery failure (missing) 6. Mains voltage is lower than 150V or higher than 250V 7. Enclosure tampering	All parameters but for communications

2.2.6 Usage

2.2.6.1. Please refer to 1.4.2 for description of ShPS-24 operation. To be admitted to work with the equipment, the personnel are obliged to have studied this manual and to have a certificate of verification of knowledge of accident prevention regulations.

2.2.6.2. Turning ShPS-24 On

IMPORTANT! Prior to turning on, ensure that the ShPS-24 is mounted properly and in compliance with the connection diagram (refer to Appendix A).

WARNING! To provide the specifications stated, the ShPS-24 box shall be operated with connected batteries in good conditions. If the batteries are connected but the ShPS-24 issues Battery Test Error, the batteries shall be replaced. The batteries of type specified in 1.2.3 shall be replaced also at the end of the battery service life stated by their manufacturer. The ShPS-24 supports a battery life counter (see Table 5). Life time set for the counter by a user shall not be more than that specified by the battery manufacturer.

a) Connect the batteries to the terminals observing polarity (with the red wire to be connected to the positive battery lead).

b) Turn on the mains power 230V, 50 / 60 Hz.

c) Apply 230V power to the box using the QF1 and QF2 circuit breakers.

Monitor the ShPS-24 status against LED indicators.

2.2.6.3. Turning ShPS-24 Off

a) Turn off the QF2 and QF1 circuit breakers.

b) Disconnect input 230 V/AC power.

c) Disconnect the batteries.

d) Disconnect the load.

2.2.7 Performance Testing

2.2.7.1. A full testing of the ShPS-24 performance is carried out only by the manufacturer or in special labs.

1) Turn on the ShPS-24 in line with 2.2.6.2.

2) Check operation of the ShPS-24, its indicators and its buzzer against Table 3. Measure the output voltage at the BK-24; it should be within the range stated in 1.2.4.

- 3) Shut off the mains power for a time of 5 minutes at least. Verify that the ShPS-24 has started to be powered by the batteries. Verify that the indicators and the buzzer operate as stated in Table 3. Measure the output voltage and verify that it is within the range stated in 1.2.4.
- 4) Turn the mains on and verify that the indicators and the buzzer operate as stated in Table 3. The ShPS-24 is considered to be operational if the requirements of items 2.2.7.1-2) – 2.2.7.1-4) are met.

2.2.7.2. ShPS-24's Batteries Capacity Measurement

To make the capacity measurement available, the battery charge level shall be more than 80%.

Note: The battery charge volume being less than 80%, the ShPS-24 cannot measure the capacity of installed batteries.

a) To measure the ShPS-24 battery capacity using the S2000M panel, please use the Test Detector function (see S2000M Users' Guide). When initiating a testing command, please specify '0' for detector address and test duration. When this command is received and executed, the ShPS-24 issues the Test Starts event. The test will be completed automatically. With this test being completed, the ShPS-24 issues the Test Ends event.

To turn the testing procedure on and off:

CODE: _	Enter a pass code.
◆ 6 SERVICE	Select the <i>Service</i> item using the ▶ ◀ buttons and press ↵, or press 6 for quick navigation.
◆ 63 TEST SYSTEM COMPONENTS	Select the <i>Test System Components</i> item using the ▶ ◀ buttons and press ↵, or press 3 for quick navigation.
◆ TEST ON	To initiate a test, please select the <i>Test ON</i> menu item using the ▶ ◀ buttons and press ↵.
ADDRESS: _	Enter the ShPS-24 address (1 to 127), or select a required one using the ▶ ◀ keys and press ↵.
COMPONENT#: _	Enter 0 for the component number and press ↵.
TIME, min: _	Enter 0 for the test duration time and press ↵.
◆ TEST OFF	To complete the capacity measurement procedure, please select the <i>Test OFF</i> item using the ▶ ◀ keys and press ↵.
ADDRESS: _	Enter the ShPS-24 address (1 to 127), or select the required one using the ▶ ◀ keys and press ↵.
COMPONENT#: _	Enter '0' as the component number and press ↵.

b) To measure the ShPS-24's battery capacity using the Orion Pro tools (see Orion Pro User Guide), please click the ShPS-24 icon on the map in the Orion Pro Monitor module, select the item next to  icon (it shows the device's address and name):

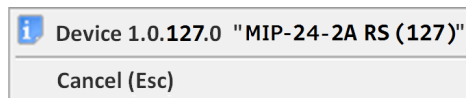

Note: The MIP-24-2A RS icon shall already be added to the map.

The following info box appears:

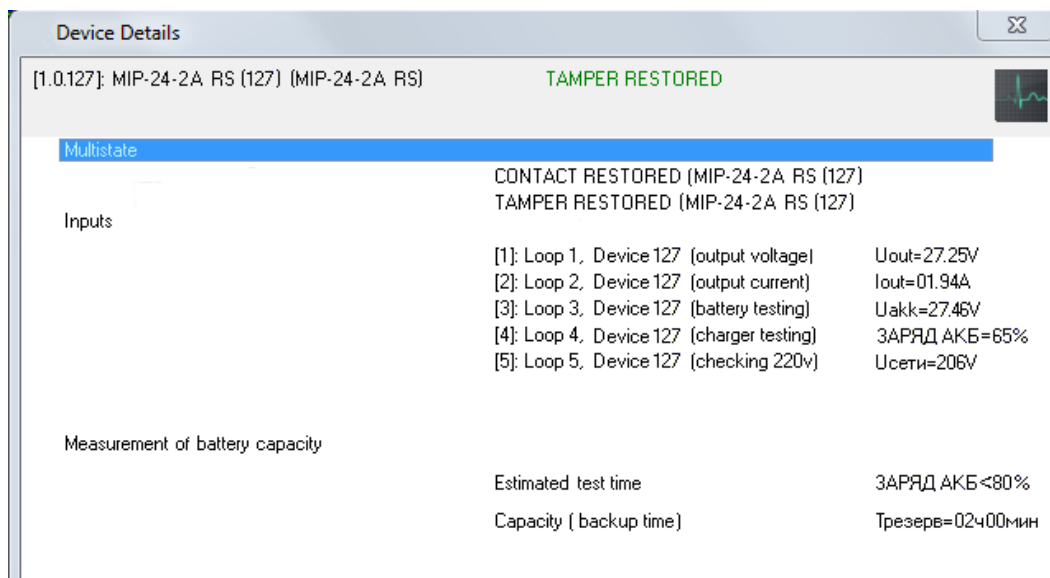

This information window provides access to ShPS-24 battery measurement control.

Click the Capacity Measurement button at the left side of the window, and the Capacity Measurement box appears to start/abort measuring the ShPS-24 battery capacity.

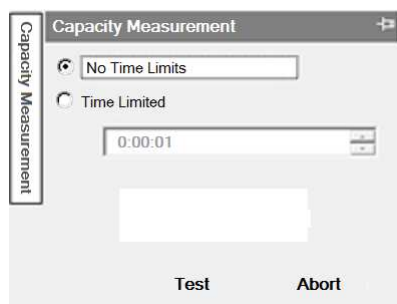

Then, select the required test option:

1. *No Time Limits*: Upon completing the test, the ShPS-24 transmits measured value of the battery capacity. The estimated time of test duration is shown in the information window. The test is completed automatically.

Note: The duration of a test correlates to the current of the ShPS-24 load.

2. *Time Limited*: The test is to be completed at the end of the time period given in the field below. This test option is recommended if you want to get info on the ShPS-24 functionality in the backup mode for the time specified. If batteries are discharged lower than 80% during the Time Limited test, the ShPS-24 can calculate the actual capacity of the batteries installed in the ShPS-24 box.

Finally, press the Test button to start the test. Pressing on Abort interrupts the test.

c) To measure actual capacity of the ShPS-24 batteries under the Sirius control panel, conduct the following (as described in the Sirius ver.1.00 User's Guide):

Repeat steps 2.2.7.2 a)... 2.2.7.2 e). At the step 2.2.7.2 b) the access group shall be assigned with test start / abort authorities.

Select the ShPS-24 with arrow buttons and press the MENU button to display the context menu for selecting operation options (see 7.5.9 of the User's Guide).

Using the Δ / ∇ button, select the Test On command in the context menu and press ENTER for sending the command to place the ShPS-24 to the battery capacity measurement mode.

In case of successive receiving of this command, the ShPS-24 executes it and issues the Test Starts event. The procedure of capacity measurement completes automatically. Upon completing the procedure the ShPS-24 issues the Test Ends event.

d) To measure the battery capacity without using commands over RS-485, conduct the following:

- 1) Make sure the batteries are charged higher than 80% (indicated by steady lit BATTERY LED);
- 2) Turn off the ShPS-24 input power;
- 3) Upon receiving a Battery Low message, apply input power, and the ShPS-24 will calculate the resulted capacity.

2.2.8 Extreme Situation Actions



Warning!

If sparks, fire, smoke, or smell of burning is found at the installation site of the product, the product must be de-energized and sent for repair

2.2.9 Troubleshooting

Table 7

Faults	Causes	Corrective Actions
ShPS-24 failed to be turned on being powered by mains	<ol style="list-style-type: none"> 1. The QF1 circuit breaker failed. 2. Wiring faults. 3. Long time overload at the output of the ShPS-24 	<ol style="list-style-type: none"> 1. Measure the voltage on mains circuit before and after the QF1 circuit breaker. 2. Repair wiring faults. 3. Power off the ShPS-24 for two or more minutes, and then power it on again.
ShPS-24 failed to be turned on being powered by batteries	The battery voltage is lower than 20 V	Check the battery voltage. Charge or replace batteries as required
ShPS-24 transmits Battery Test Error message	<ol style="list-style-type: none"> 1. Significantly reduced battery capacity. 2. Battery leads oxidation or loosened battery contacts 	<ol style="list-style-type: none"> 1. Replace batteries. 2. Clean leads; tighten wire connections of the battery.
ShPS-24 issues the Service Required message	Battery lifetime expired	Replace the batteries and reset the lifetime counter
Lost communications between the ShPS-24 and the network controller	<ol style="list-style-type: none"> 1. Failed connection between the ShPS-24 and the controller. 2. Wrong connection of transmission path to A and B interface contacts 	<ol style="list-style-type: none"> 1. Restore connection; meet the requirements as to 2.2.5.4 of this manual. 2. Swap the transmission path wires connected to A and B contacts of the RS-485 interface
The controller transmits the Communication Lost event	<ol style="list-style-type: none"> 1. Open-circuit failure on the transmission path. 2. The ShPS-24 has turned off the transceiver due to a low battery charge 	<ol style="list-style-type: none"> 1. Recover connection. 2. Take measures to recover mains supply

3 Maintenance

3.1 General

ShPS-24 shall be maintained in line with the following schedule:

Table 8

Task Description	Frequency
Visual inspecting of the ShPS-24 box	Monthly
Inspecting of proper operation of ShPS-24 powered from both power supplies	Six-monthly

3.2 Safety Precautions

The product shall be maintained by personnel qualified for the Electrical Safety of Level III or higher.

3.3 Maintenance Procedures

3.3.1 To inspect the ShPS-24 and batteries visually means verifying they have no mechanical damage and are fastened reliably, conditions of connecting wires and contact joints are good, and batteries are undeformed with no electrolyte leakage.

3.3.2 Inspecting of proper operation of ShPS-24 powered from both power supplies is conducted against the procedures of 2.2.7.1-2) – 2.2.7.1-4).

Note: Operating temperatures above 25 degrees C dramatically reduce battery service life (see specifications of the manufacturer of the battery installed).

3.4 Operability Testing

Test operability of the ShPS-24 in accordance with 2.2.7.1.

3.5 Technical Examination

Technical examination is not applicable for this equipment.

3.6 Preservation (Depreservation, Represervation)

Preservation is not applicable for this equipment.

4 Repair

Repair of faulty equipment is to be conducted by the manufacturer or in authorized repair centers. The product shall be sent for repair in compliance with Company Standard QMS 8.5.3-2015, which can be found online at our website <https://bolid.ru/support/remont/>.

ATTENTION!

The manufacturer accepts no claims unless a malfunction report is applied.



Attention!

The equipment shall be submitted for repair being assembled and clean and along with all the parts listed in the documentation.

Claims are accepted only if a reclamation report describing the failure in question is applied to the submitted equipment

A ShPS-24 failure resulted from consumer's not observing rules of mounting and operation is not a reason for claims and warranty repair.



Warning!

Removing the PC board(s) of MIP-24 and/or BK-24 from the ShPS-24 cabinet automatically voids the manufacturer's warranty

Claims should be submitted to the following address:

NVP BOLID, #4 Pionerskaya Str., Korolyov, Moscow Region, 141070, Russia

Phone/fax: +7 (495) 775-71-55 (PBX) E-mail: info@bolid.ru

In case of any issue related to use of the product, please contact the technical support: +7 (495) 775-71-55 or e-mail: support@bolid.ru

5 Storage

Storage in a transport container is permitted at ambient temperatures -30°C through +50°C and relative humidity up to 95% at +35°C.

Storage in the consumer package is permitted only in heated premises at temperatures +5 through +40°C and relative humidity up to 80% at +20°C.

6 Transporting

The ShPS-24 box can be transported in a transport container at ambient temperatures minus 50 through +50°C and relative humidity up to 95 % at +35°C.

7 Disposal

The product can be disposed of considering that there are no toxic components in it.

Batteries are classed as hazardous waste of Class II, so used up batteries shall be disposed of by a specialized company that is licensed for this activity.

The content of precious materials: doesn't require accountability for storage, retirement, and disposal (Clause 1.2 of GOST 2.608-78).

The content of non-ferrous metals: does not require accountability for retirement and further disposal.

8 Manufacturer Warranty

8.1 The manufacturer guaranties the ShPS-24 meets with technical requirements stated in the manuals if the user follows the instructions for transportation, storage, installation, and usage.

8.2 The warranty period is 18 months since putting the product into operation but no more than 24 months from the manufacturer's date of production.

9 Certification Information

9.1 ShPS-24, ShPS-24 mod.01, ShPS-24 mod.02, ShPS-24 mod.10, ShPS-24 mod.11, ShPS-24 mod.12 meet the requirements of Technical Regulations of Custom Union TR CU 004/2011, TR CU 020/2011 and are covered by Conformity Declaration EAЭC № RU Д-РУ.НA74.В.00197/19.

9.2 ShPS-24, ShPS-24 mod.01, ShPS-24 mod.02, ShPS-24 mod.10, ShPS-24 mod.11, ShPS-24 mod.12 meet the requirements of TR EAEU 043/2017 'On Requirements for Fire Safety and Fire Extinguishing Equipment' and are covered by the conformity certificate No. RU C-РУ.ЧC13.В.00108/21.

9.3 Production of ShPS-24 is awarded with the conformity certificate GOST R ISO 9001. The certificate can be found at the website <http://bolid.ru> in the section ABOUT COMPANY.

Appendix A

Schematic for Wiring ShPS-24, ShPS-24 mod.01, ShPS-24 mod.02

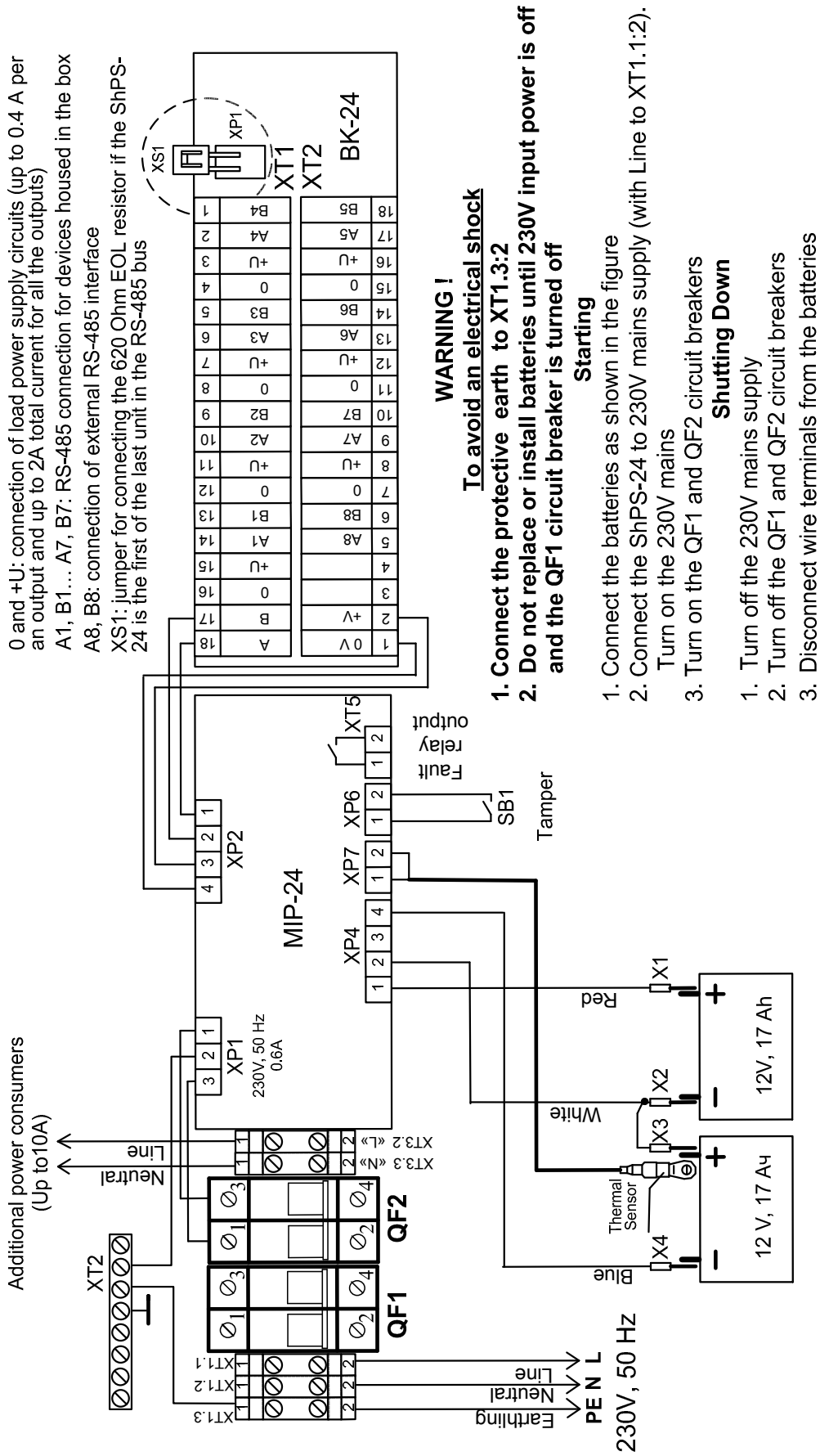

Schematic for Wiring ShPS-24 mod.10, ShPS-24 mod.11, ShPS-24 mod.12

- 0 and +U: Connection of load power supply circuits (up to 0.4A per one of the outputs XT1...XT6, up to 0.6A per output XP3, up to 2A total current for all the outputs).
 A, B: Connection to RS-485 interface with the devices housed in the box.
 A1, B1: Connection to the first separate interface RS-485.
 A2, B2: Connection to the second separate interface RS-485.

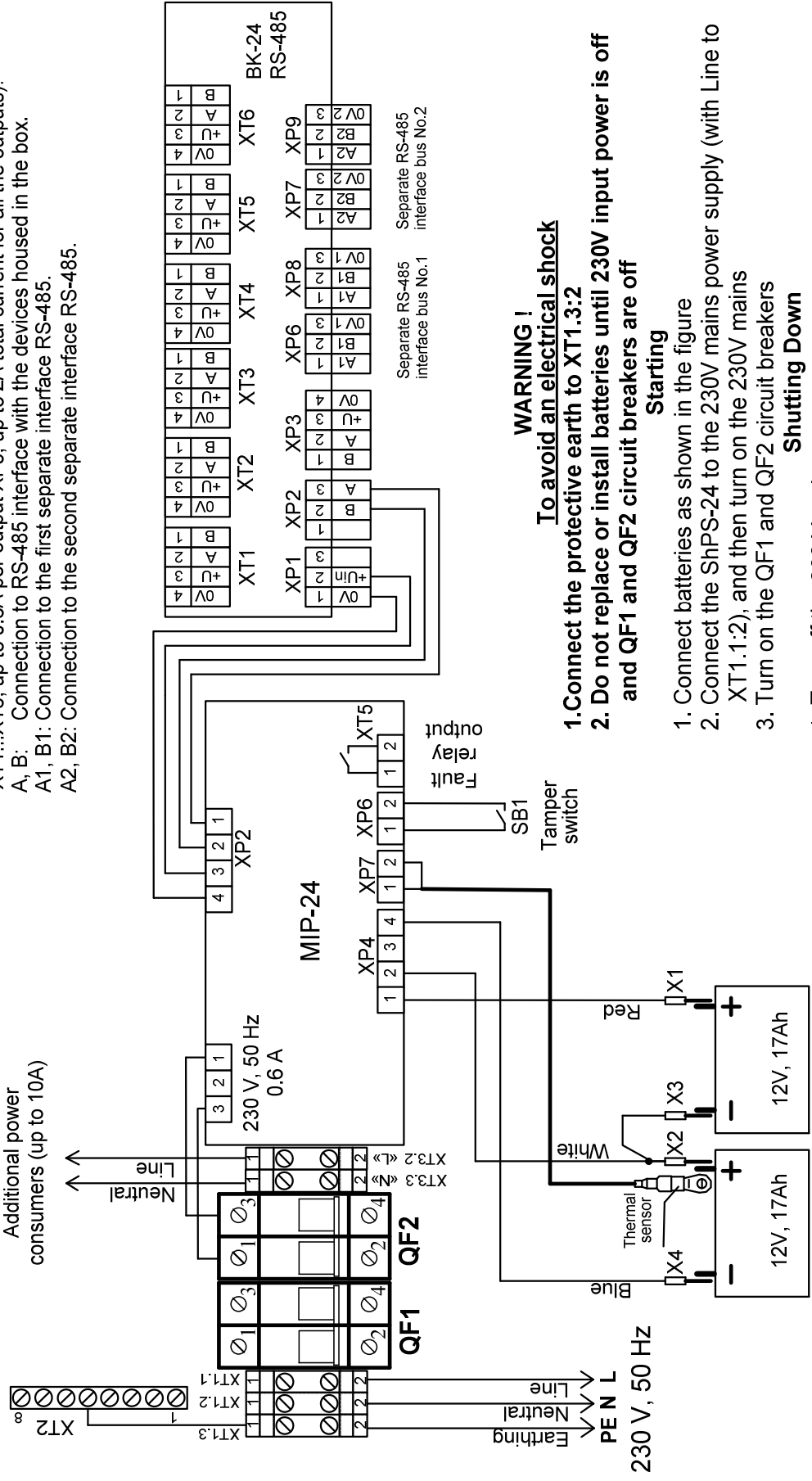

WARNING !
To avoid an electrical shock

1. Connect the protective earth to XT1.3:2
2. Do not replace or install batteries until 230V input power is off and QF1 and QF2 circuit breakers are off

Starting

1. Connect batteries as shown in the figure
2. Connect the ShPS-24 to the 230V mains power supply (with Line to XT1.1:2), and then turn on the 230V mains
3. Turn on the QF1 and QF2 circuit breakers

Shutting Down

1. Turn off the 230 V mains power
2. Turn off the QF1 and QF2 circuit breakers
3. Disconnect terminals from the batteries

Appendix B

(For reference)

Example No.1 of fitting together equipment within ShPS-24

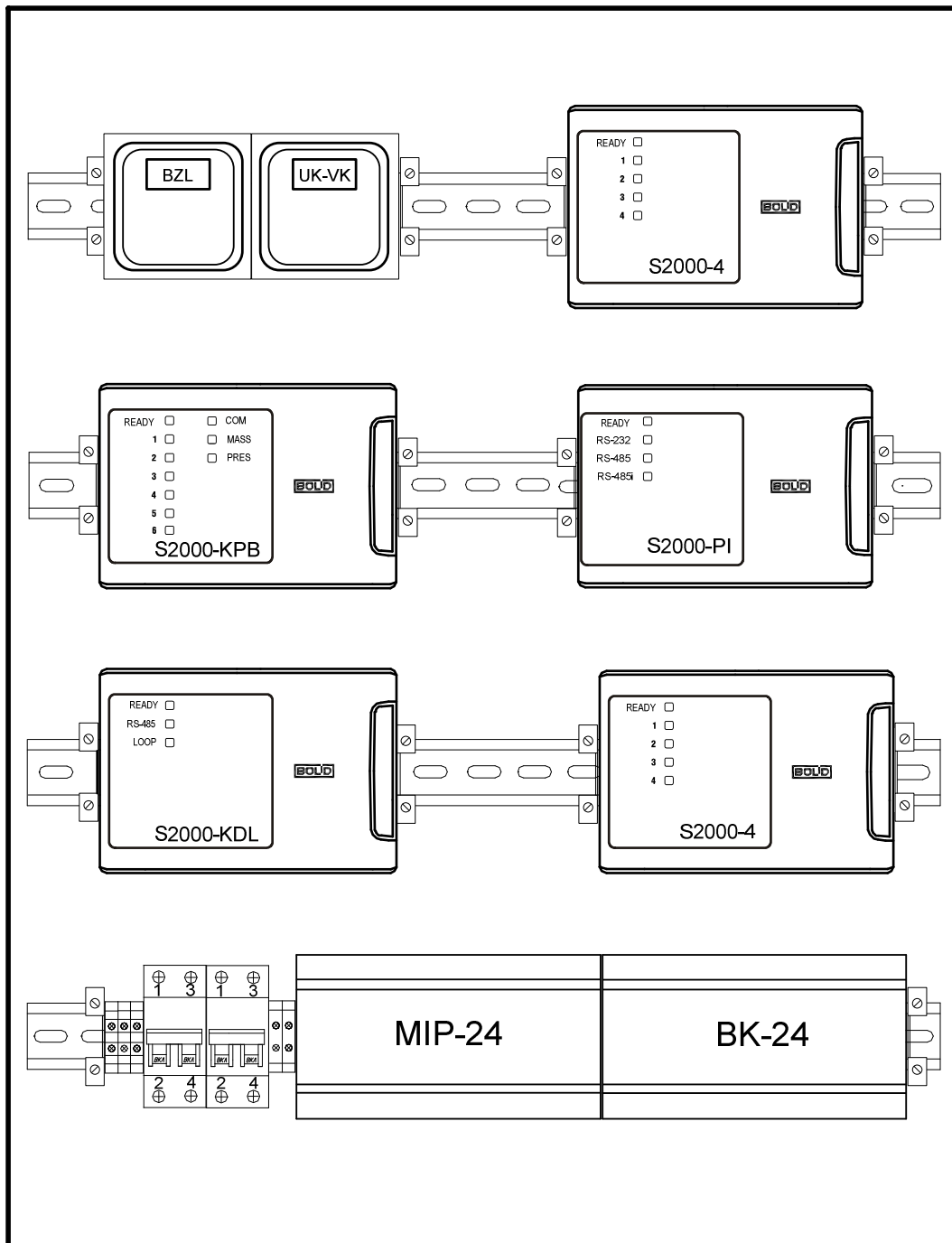

Appendix C

(For reference)

Example No.2 of fitting together equipment within ShPS-24

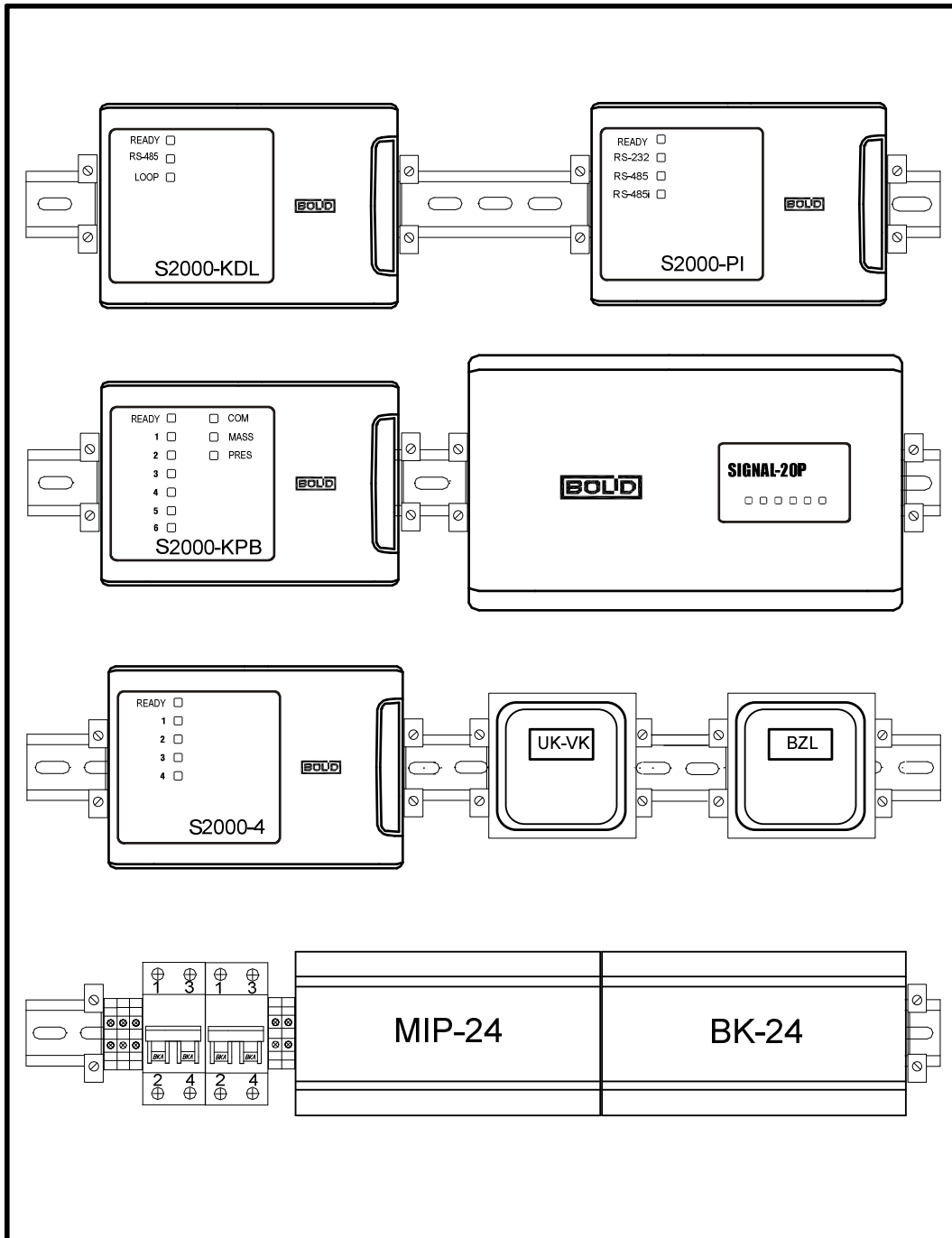

Appendix D

(For reference)

Example of Arranging Equipment on the Door of ShPS-24, ShPS-24 mod.02, ShPS-24 mod.10, or ShPS-24 mod.12 using MK-1 ShPS Mounting Kit

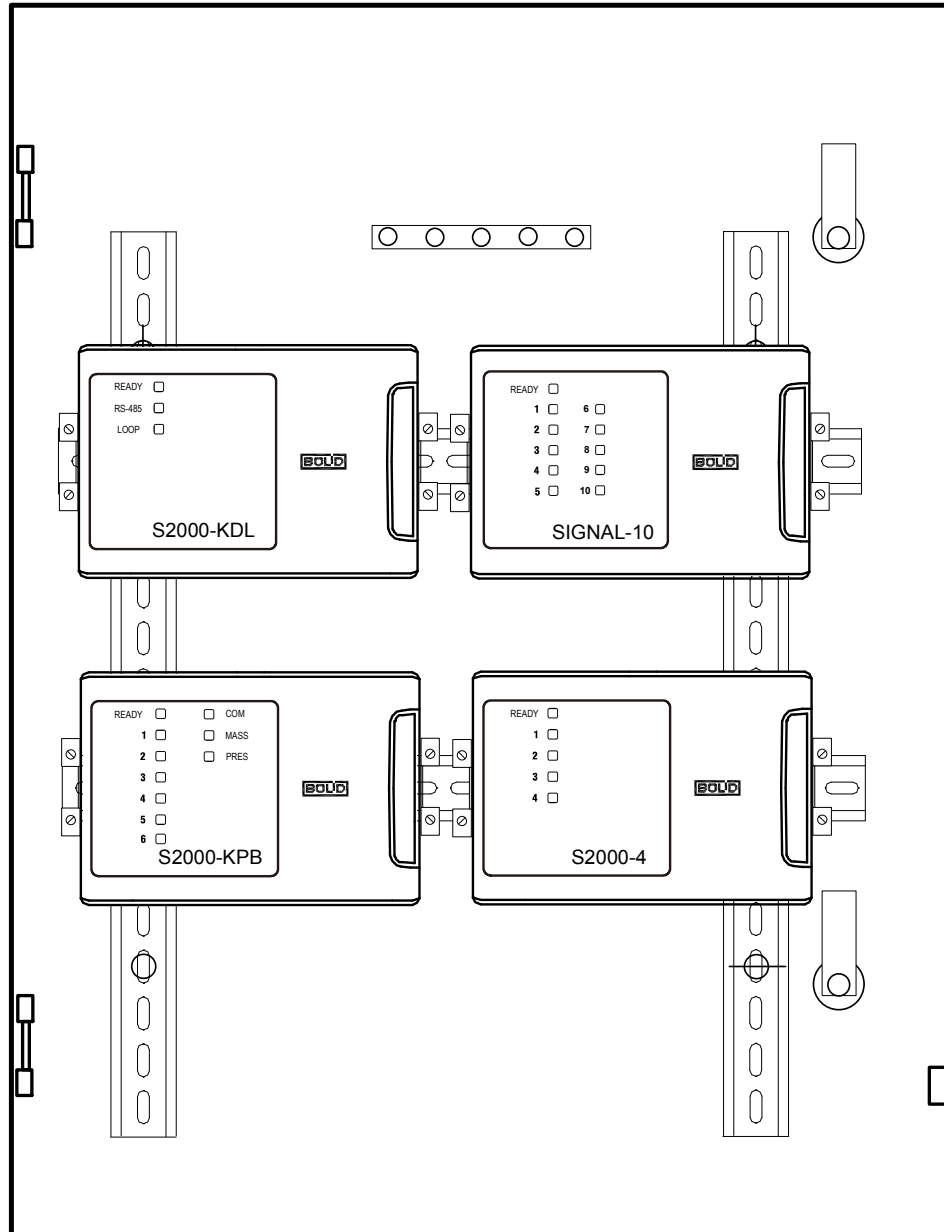

Appendix E

Overall and Mounting Dimensions For ShPS-24, ShPS-24 mod.02, ShPS-24 mod.10, ShPS-24 mod.12

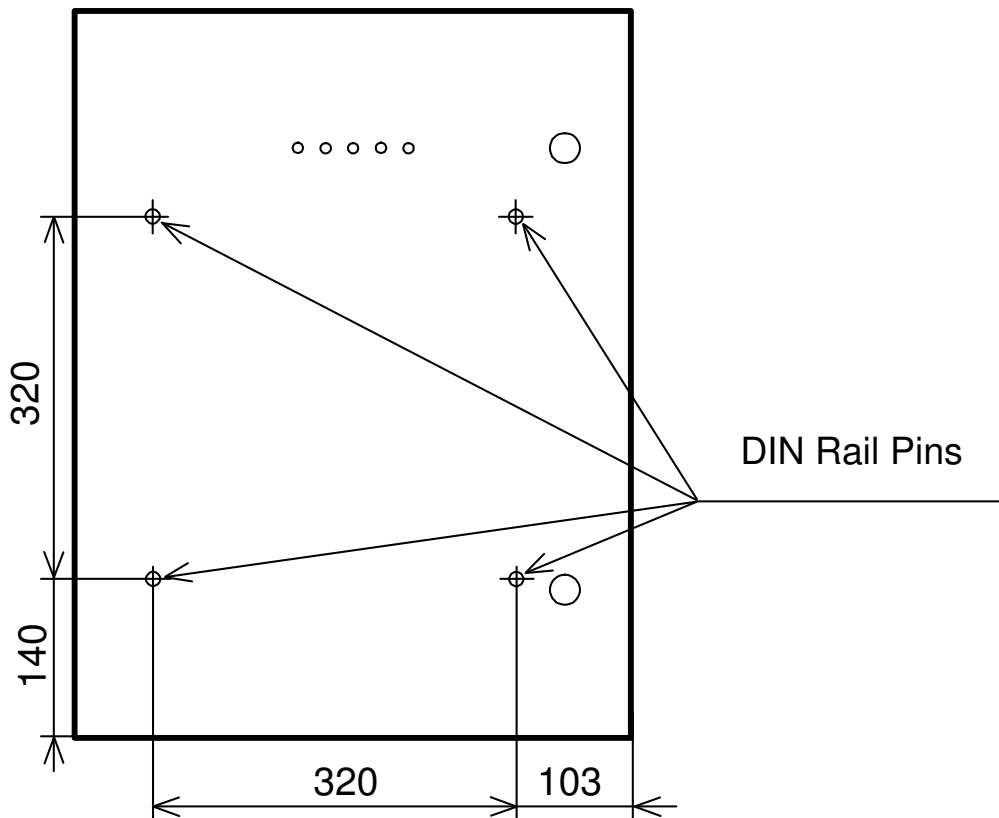
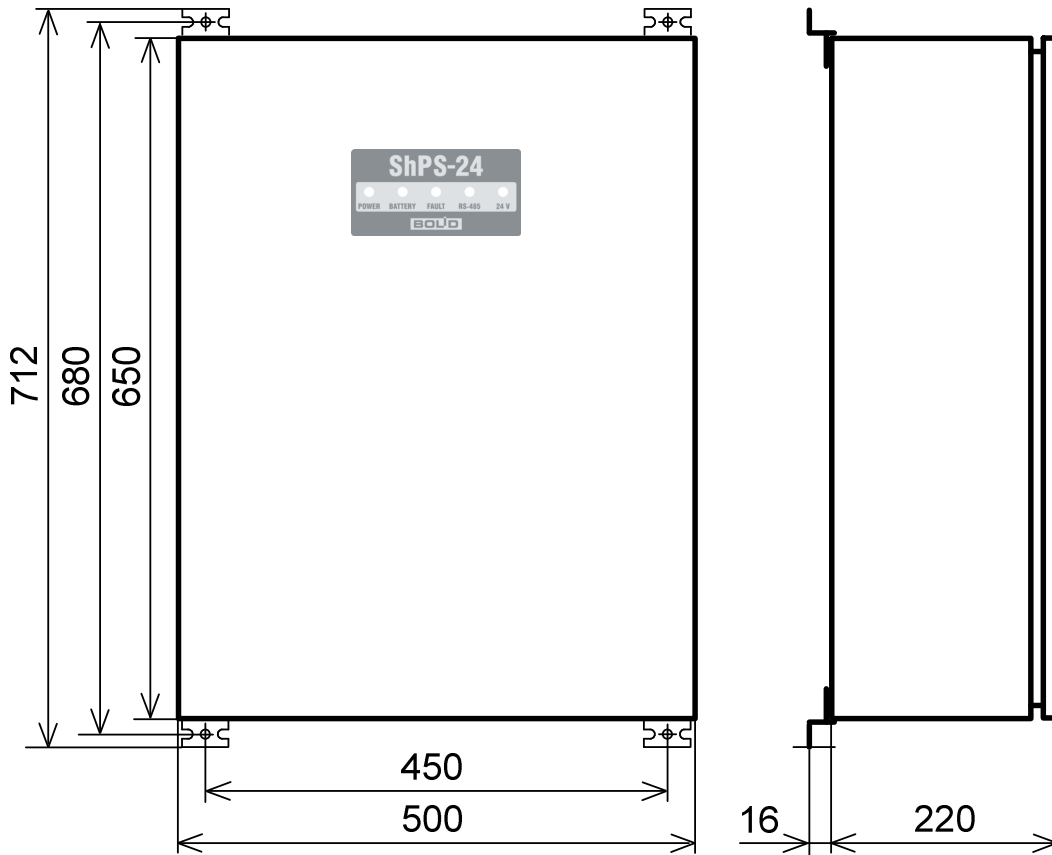

Appendix F

Overall and Mounting Dimensions For ShPS-24 mod.01 and ShPS-24 mod.11

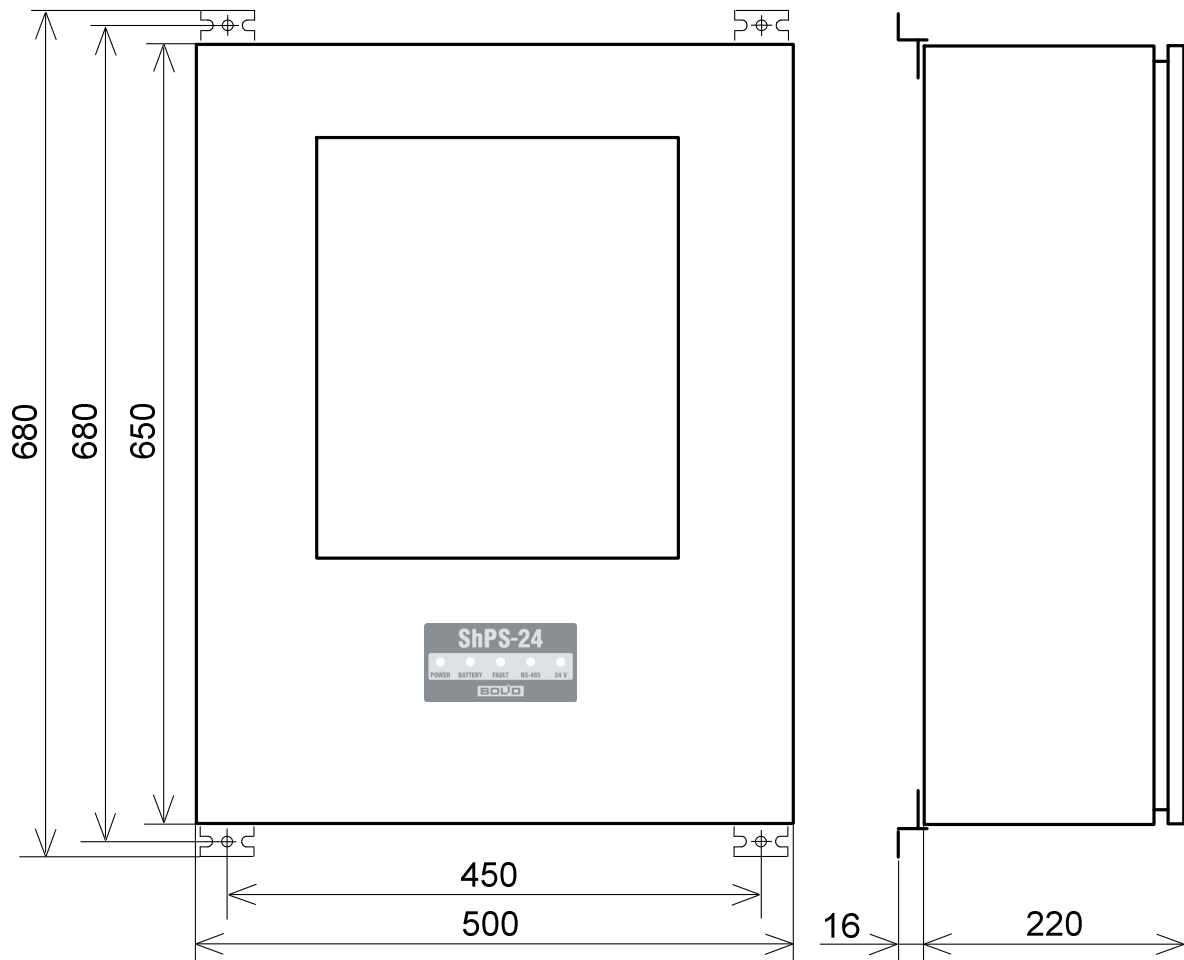

Appendix G

(For reference)

Window Sizes and Position on the Door ShPS-24 mod.01 and ShPS-24 mod.11

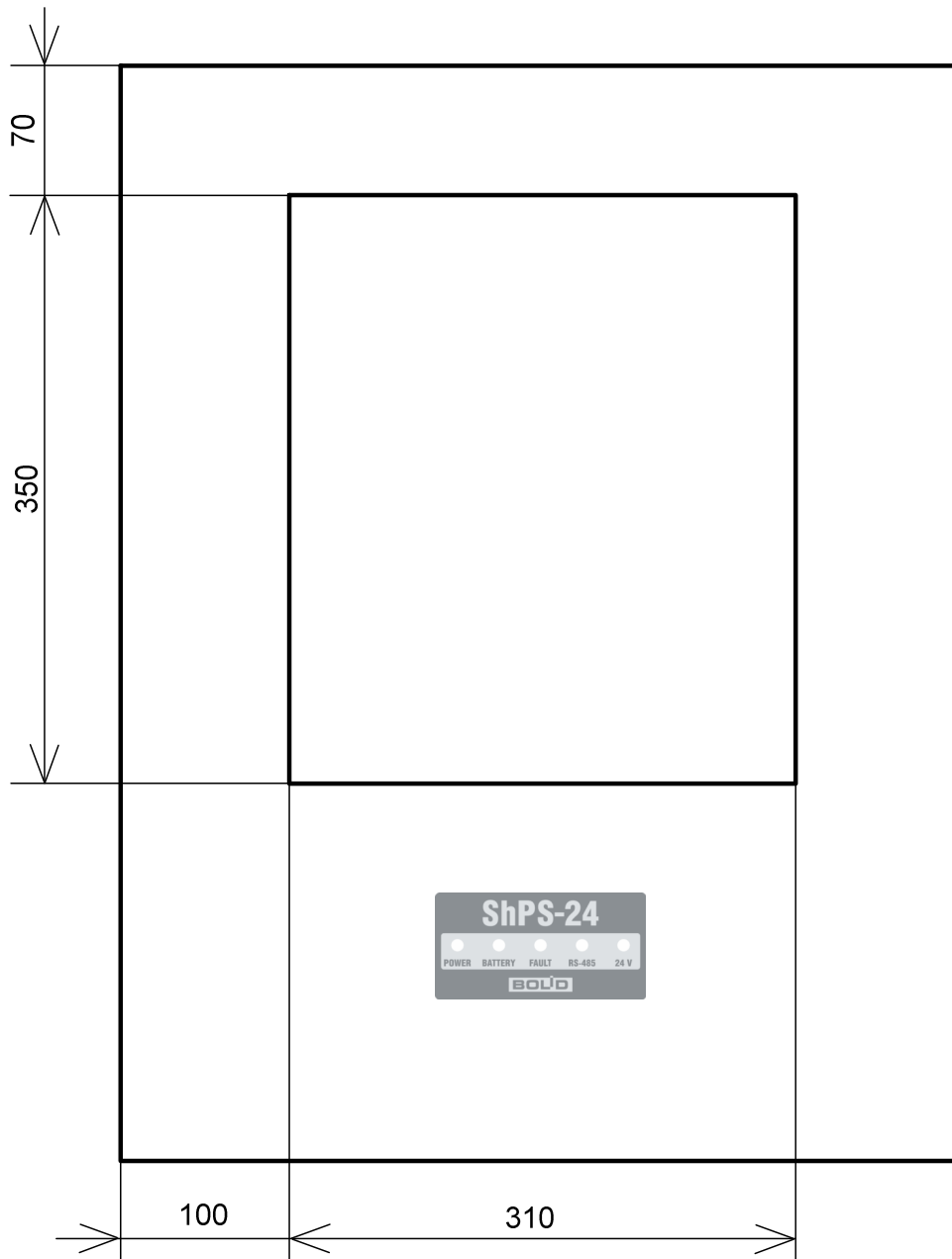

Appendix H

(For information)

UProg Window for Programming ShPS-24

UPROG Address: 127 MIP-24 RS(ver. 1.00)

File Settings Device Language Help

Event Delays

Mains Restored Event 4

Mains Failed Event 4

Battery life left before the Service Required status

Years 5

Service Required message repeats every

Hours 255

Parameter	Value
Output Voltage	Uout=26,89V
Output Current	Iout=02,01A
Battery Voltage	Uakk=27,12V
Charger Condition	ЗАРЯД АКБ:63%
Mains Voltage	Усети=218V
Battery Life Counter	5 год 0 мес.
Backup Time	Трезерв=04ч28мин
Battery Capacity	Емкость не изм.

Read Parameters

SSR (maximum switched 80V voltage and 100mA current)

Control Program Turn Off if Failed

Relay Activation Time 8191,875

Select relay control options

All parameters but for communications	+
Communications fault	
Output current overload	+
RIP failure (charger, Uout)	+
Battery failure (missing)	+
Mains voltage is lower than 150V or higher than 260V	+
Tamper Alarm *	+

* Operation time for this parameter is 15 sec longer than a value set

Mains Voltmeter Adjustment

Adjustment value, V 0

Unit / Protocol