

1 TECHNICAL DATA

1.1 General

IPR 513-3AM Rev.02 Addressable Resettable Manual Call Point (hereinafter referred to as the call point) is to be used with a polling loop controller S2000-KDL or S2000-KDL-2I (hereinafter referred to as the PLC) within an Orion integrated security system. The call point is intended for triggering a fire alarm or actuating a fire suppression system manually.

The call point is powered and communicates data with a PLC over the controller's Polling Loop (hereinafter referred to as the PL). The call point supports DPLS_v2.xx Multiplex Addressable Polling Loop Protocol providing monitoring PL voltage at the detector's location. The version of IPR 513-3AM Rev.02 firmware is 1.01.

The transparent protective flip cover of the call point can be sealed.

The call point is intended for round-the-clock operation and is repairable and serviceable.

1.2 Specifications

- | | |
|--|-------------------------|
| 1) Polling Loop Voltage | - 8 to 11 V |
| 2) Consumed Current | - 0.5 mA max |
| 3) Pre-operation Time | - 15 s max |
| 4) Ingress Protection Rating | - IP20 |
| 5) Operating Temperatures | - Minus 30°C to +55°C |
| 6) Transportation and Storage Temperatures | - Minus 50°C to +55°C |
| 7) Relative Humidity | - Up to 93% at 40°C |
| 8) Overall Dimensions | - 94 mm × 94 mm × 54 mm |
| 9) Weight | - 0.15 kg max |
| 10) The content of precious materials: does not require accountability for storage, retirement and disposal. | |

1.3 Standard Delivery

For an *individual* delivery:

- | | |
|----------------------|-----------|
| - IPR 513-3AM Rev.02 | - 1 pc.; |
| - Instruction Manual | - 1 copy; |
| - Special Key | - 1 pc.; |
| - Screw 3.5×20 | - 2 pcs.; |
| - Screw 3×13 | - 2 pcs.; |
| - Wall Plug 7×22 | - 2 pcs.; |
| - Package | - 1 pc. |

For a *group* delivery:

- | | |
|----------------------|------------|
| - IPR 513-3AM Rev.02 | - 10 pcs.; |
| - Instruction Manual | - 1 copy; |
| - Special Key | - 10 pcs.; |
| - Screw 3.5×20 | - 20 pcs.; |
| - Screw 3×13 | - 20 pcs.; |
| - Wall Plug 7×22 | - 20 pcs.; |
| - Package | - 10 pcs.; |
| - Group package | - 1 pc. |

2 OPERATION INSTRUCTIONS

2.1 Wiring and Setting

Figure 1 shows a typical diagram for connecting the call point to a PLC.

In PLC configurations the input type for the call point is set to the value "3" - "Heat Fire" (with generating Fire messages) or "16" - "Manual Fire" (with generating Fire 2 messages). The input type also can be set to "6" - "Auxiliary".

	Input Types 3 and 6	Input Types 6 and 16
S2000-KDL	For ver.2.05 and below	For ver.2.10 and higher
S2000-KDL-2I	For ver.1.05 and below	For ver.1.10 and higher

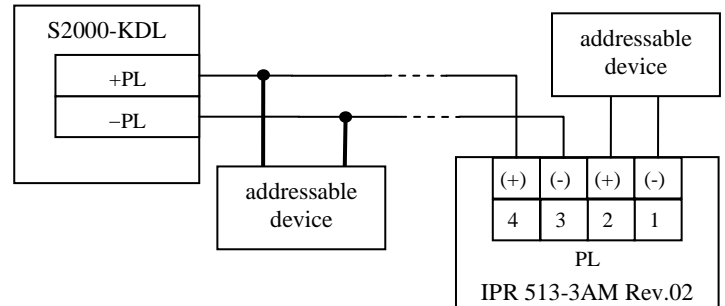

Figure 1

2.2 Mounting

The call point (see Figure 2) is to be mounted using the two screws to a wall in accordance with your applicable local standards, codes, regulations, and ordinances. The installation order is as follows.

Attach the base (3) with two woodscrews (7) to the wall. Then remove the front cover (1) from the central frame (2) and connect the wires passed through the base to the terminal block on the central frame. Next, fasten the central frame to the base with two woodscrews (6). And finally put the front cover on the assembled unit.

Figure 2 shows the call point in disassembled state:

- 1: Front cover;
- 2: Central frame;
- 3: Base;
- 4: Protective glass;
- 5: Special key;
- 6: Screws 3×13;
- 7: Screws 3.5×20.

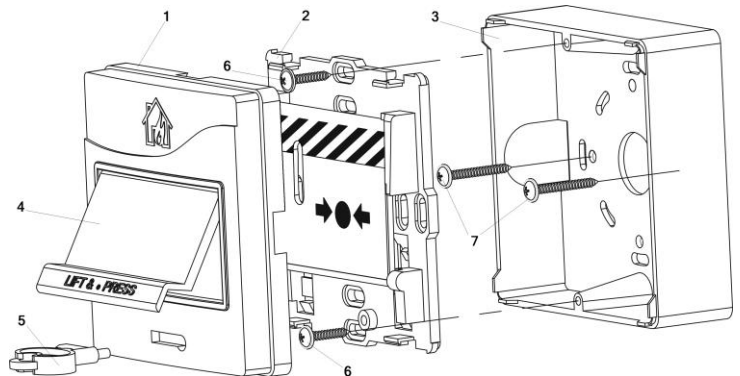

Figure 2

2.3 LED Indication

LED Performance	Condition (Event)
Flashes every 4 seconds	OK
Flashes twice every 4 seconds	Fire 2 Alarm (the Fire Button is activated)
Flashes four times every 4 seconds	Programming mode

2.4. Setting a Call Point Address

The call point provides storing its PL address in its non-volatile memory. The address can be assigned in the range 1 to 127. The factory address value is 127.

In order to assign a polling loop address to the call point, send one of the following commands from the S2000M panel or the connected personal computer to the PLC:

Set the Device Address

If the call point address is unknown or two devices have the same address then use the *Set Device Address* command specifying a required address as the parameter. When the call point receives the command its LED starts flashing four times every four seconds. Then, not later than 5 min since receiving the command activate the call point twice within 10 s (with the duration of pushing of 0.5 s to 3 s and the pause between presses of 0.5 s to 4 s). Verify that a message about detecting the device with the newly assigned address is displayed by a network controller (S2000M) or UProg Configuration Tool.

Change the Device Address

Use the *Change Device Address* command specifying the old device address and the new device address as the parameters (see more information in the referred Manuals). The network controller will display the messages about disconnecting the device with the old address and then detecting the device with newly programmed address.

2.5. Routine Testing

2.5.1. Before testing the call point, please disconnect executive outputs of all system devices and modules that can release extinguishing agent or activate light and sound alarms. Notify the proper authorities that the system is undergoing maintenance.

2.5.2. Arm the call point by means of the S2000M panel or the PC.

2.5.3. Activate the call point by pushing the key. Verify that the call point's LED flashes twice every four seconds indicating triggering an alarm and that the network controller indicates a Fire 2 Alarm message for the address of the call point.

2.5.4. Reset the call point to its Norm state by inserting the special key provided (5 in Figure 2) and turning it in the relevant keyhole. Verify the call point LED starts flashing once per 4 s. From the panel or PC issue a command to cancel the alarm sent by the call point.

If no Fire 2 alarm has been received by the network controller, it means that the call point is defective and must be replaced.

2.5.5. Repeat steps 2.5.2 – 2.5.4 three times or more.

2.5.6. After testing, verify that the call point is ready to operate properly. Then restore operability of all the system components disconnected before testing and notify the proper authorities that the system is back in operation.

2.5.7. Inspect activation of the call point at least once per three months.

All the equipment used in testing must be known functioning.

3 MAINTENANCE

The call point should be maintained at least annually by specialists with at least third electrical safety qualification level.

Maintenance works shall include:

- Ensuring the call point casing is not damaged and wire terminals are fastened properly;
- Removing dust, debris, and corrosion from the contact connections and the casing of the call point;
- Testing operability of the call point as discussed in Clause 2.5 of this manual.

4 MANUFACTURER WARRANTY

4.1 The average lifetime of the IPR 513-3AM Rev.02 is at least 10 years.

4.2 The manufacturer warrants its product to be free from defects in materials and workmanship under normal use and service for 18 months since putting it into operation, but no more than 24 months since the acceptance date.

4.3 If you have any problems with configuring and operating the call point please contact the technical support by phone +7 495 775-7155 or by email support@bolid.ru.

4.4 While submitting the product for repair, please apply a report describing the potential failure.

Submit your claims to the address: ZAO NVP Bolid, 4 Pionerskaya Str., Korolev 141070, Moscow Region, Russia.

Phone/fax: +7 495 775-7155 (PBX), +7 495 777-4020, +7 495 516-9372.

E-mail: info@bolid.ru, Technical Support: support@bolid.ru, <http://bolid.ru>.

5 CONFORMITY CERTIFICATES

5.1 IPR 513-3AM Rev.02 Addressable Resettable Manual Call Point is approved by Conformity Certificate No. C-RU.IIB01.B.02389.

5.2 Conformity Declaration TC № RU Д-РУ.ME61.B.00356 certifies that IPR 513-3AM Rev.02 meets the requirements of Technical Regulations of Customs Union TR CU 020/2011.

5.3 Production of IPR 513-3AM Rev.02 is certified in line with Russian Standard GOST ISO 9001–2011 by a Conformity Certificate No. POCC RU.ИК32.K00153.

6 PRODUCT ACCEPTANCE CERTIFICATE

IPR 513-3AM Rev.02 addressable manual call points (the serial numbers are inside their cases) are accepted in accordance with mandatory requirements of state standards and current technical documentation, qualified as proper for operation and packaged by CJSC NVP “Bolid”.

Responsible for acceptance and packaging



Made in the Bolid Company
RUSSIA

QCD

Full Name

Date, Month, Year