

1 MAIN SPECIFICATIONS

1.1 General

The S2000-KT Addressable Panic Button (hereinafter called the Button) is meant for issuing panic signal manually when operated in the Orion Integrated Security System. Power supply and communication are provided via the Polling Loop (PL) of the S2000-KDL or S2000-KDL-2I Polling Loop Controller (hereinafter called PLC). The Button is meant for 24/7 continuous operation and related to the repairable and serviceable products.

1.2 Specifications

- | | |
|---|-------------------------|
| 1) Enclosure protection | : IP 41 |
| 2) Climatic category (OST 25 1099-83) | : O3 |
| 3) Signal line voltage | : 8V to 10V |
| 4) Consumption current | : 0.5 mA max |
| 5) Startup time | : 15 sec max. |
| 6) Operating temperatures | : - 30°C to +50°C |
| 7) Humidity | : up to 93% at +40 °C |
| 8) Shipment temperature | : - 50°C to +50°C |
| 9) Dimensions | : 100x55x28mm max |
| 10) Weight | : 45g max |
| 11) MTBF in quiescent mode | : 80,000 hours at least |
| 12) Non-failure operation probability | : 0.98758 |
| 13) The content of precious material: does not require accounting for storage, retirement, and disposal | |

1.3 Standard Delivery

- | | |
|-------------------------|----------|
| - S2000-KT Panic Button | : 1 pcs. |
| - Data Sheet | : 1 pcs. |
| - Grommet | : 2 pcs. |
| - Screw 1-3x25.016 | : 3 pcs. |
| - Nail Plug 6x30 | : 3 pcs. |
| - Package | : 1 pcs. |

2 OPERATION INSTRUCTIONS

2.1 External Connection and Mounting

Figure 1 shows the standard connection of the button to the S2000-KDL. The following input types can be used with this button: 4-Intrusion (Normal and Alarm states), Auxiliary (Normal and Alarm). For description of input types and settings see the users' manuals for Orion Pro Suite or S2000-KDL.

The button is mounted using supplied screws (see Figure 2 for installation dimensions).

2.2 Setting Button Address

The Button's polling loop address is stored in the non-volatile memory. The range of selectable addresses is from 1 to 127. The default button address: 127.

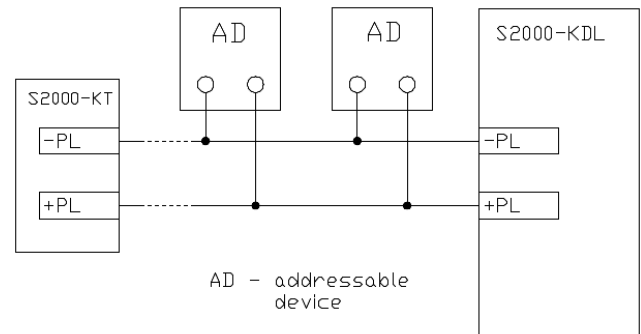

Figure 1 Wiring Diagram

To assign an address, please use the S2000M panel or Orion Pro workstation to initiate the **Change Device Address** command with specified old and new button addresses. When the command is initiated, the S2000M or Orion Pro Workstation displays messages the button is disconnected with old address and connected with the new one.

The **Assign Device Address** command can assign an address to the button regardless of what address it has at the moment. It can be useful in case of a wrong assignment of the same address to two or more system addressable devices. Please use the S2000M or Orion Pro workstation to issue a command containing a required address number. Put the Button in a ready-to-work (initial) position by pulling up the brace edges till it cannot go further. Then press the button and return it back to the initial position. These procedures shall be performed twice within ten seconds. The panel or workstation displays messages on connecting the button with the assigned address. If devices had the same address, no old address disconnection messages can be appeared.

2.3 Testing Button

Please, arm the button using the S2000M panel or Orion Pro workstation. When pressing the button make sure that the alarm signal appears on the panel or workstation from the corresponding address point. Otherwise the button is failed and shall be replaced.

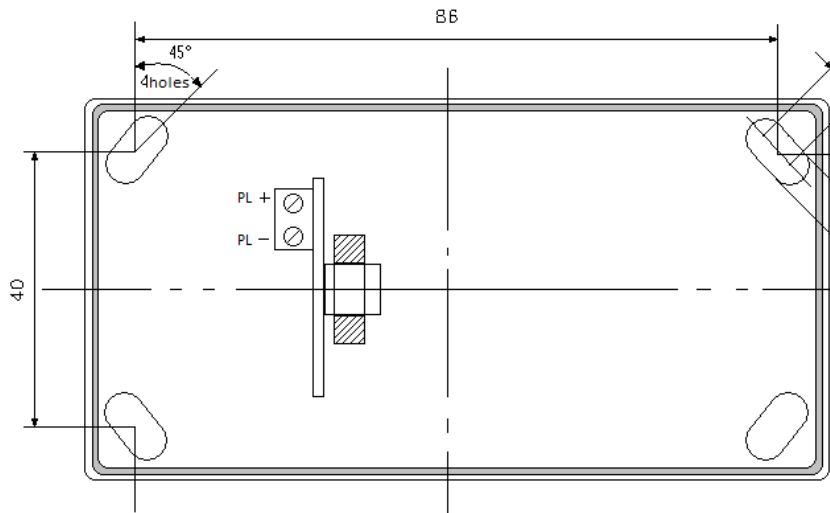

Figure 2 Mounting Dimensions

All testing shall be carried out with good working equipment!

3 MAINTENANCE

The maintenance service for the button shall be provided at least once per year by professionals qualified for Electrical Safety of Level III or higher.

The maintenance shall include the following:

- a) Inspection for physical damage, reliability of fastening, and terminals tightening;
- б) Cleaning the button terminals and enclosure from dust, grease and corrosion;
- в) Functionality tests according to para 2.3 of this datasheet.

4 WARRANTY

4.1 The average lifetime is eight years at least.

4.2 The warranty period is five years from the manufacturer's date of issue provided the installation and usage conditions are fully complied.

4.3 In case of any issues related to configuration and usage of the product, please contact with the technical support: +7 (495) 775-71-55 or e-mail: support@bolid.ru.

4.4 When submitting the panel for repair, it shall be accompanied with descriptions of possible fault. All claims shall be submitted to:

NVP Bolid, Russia. Pionerskaya #4, Korolyov city, Moscow region, Russia, 141070.

Phone/Fax: +7 (495) 775-71-55 (multiline), **777-40-20, 516-93-72.**

E-mail: info@bolid.ru; <http://bolid.ru>

5 CERTIFICATIONS AND APPROVALS

5.1 The S2000-KT Addressable Panic Button ACDR.425111.001 complies with the requirements of Technical Regulations of the Customs Union TR CU 020/2011 and has Certificates of Conformity No RU C-RU.ME61.B.01497.

5.2 The S2000-KT Addressable Panic Button has Certificate of Conformity No BY/112 03.11.023 01297.

5.3 The S2000-KT Addressable Panic Button ACDR.425111.001 is awarded with certificate of conformity of Transportation Security Facilities with the requirements to their functional properties No. МБД РФ.03.000036.

5.4 The production of the S2000-KT is awarded with Certificate of Conformity GOST ISO 9001 – 2011 № ПОСС RU.ИК32.К00153.

6 DIFFERENCES AS COMPARED WITH PREVIOUS VERSIONS

Version	Start of issue	Version for change	Changes	Compatibility
1.00	08.2008	–	Start of production	S2000-KDL and S2000-KDL-2I (all versions)

7 ACCEPTANCE CERTIFICATE

The S2000-KT Addressable Panic Button ACDR.425111.001, serial No. _____ manufactured and accepted in accordance with requirements of national standards and applicable technical documentation is approved as ready for use and packaged by the Bolid Company.

Responsible for the acceptance and package

QCD

_____ Name

_____ Date/month/year