

# S2000-SMK

## ADDRESSABLE MAGNETIC CONTACT

Version 1.03

### INSTRUCTION MANUAL

#### DESCRIPTION

S2000-SMK Addressable Magnetic Contact is a magnetic intrusion switch designed to provide detection of unauthorized incursions into protected premises. It is to be surface-mounted on a door or a window sash within a protected area.

The S2000-SMK is a part of an Orion safety & security system and operates under an S2000-KDL controller of versions 2.00+. The S2000-SMK is powered by and communicates data through the multiplex addressable polling loop of the S2000-KDL. Consult the S2000-KDL instructions for compatibility.

The software version of the S2000-SMK is 1.03.

The S2000-SMK contact is designed for round-the-clock operation.

#### SPECIFICATIONS

Ingress Protection Rating	IP41
Input Power Voltage	8 ÷ 12 V from an S2000-KDL via its two-wire multiplex polling loop
Maximum Current Rating	0.5 mA
Maximum Pre-Operation Time	15 s
Operating Temperatures	-30 C to +50 C
Relative Humidity	up to 95% (for +25 C) non-condensing
Handling/Storage Temperatures	-50 C to +50 C
Gap Distance	10 ÷ 25 mm
Overall Dimensions:	
Switch	56×10×8 mm
Magnet	56×10×8 mm
Weight	about 10 g
Average Lifetime	8 years

#### STANDARD DELIVERY

S2000-SMK Magnetic Contact	1 pcs.
Slotted Countersunk Flat Tapping Screw	4 pcs.
Instruction Manual	1 pc.
Package	1 pc.

#### MOUNTING

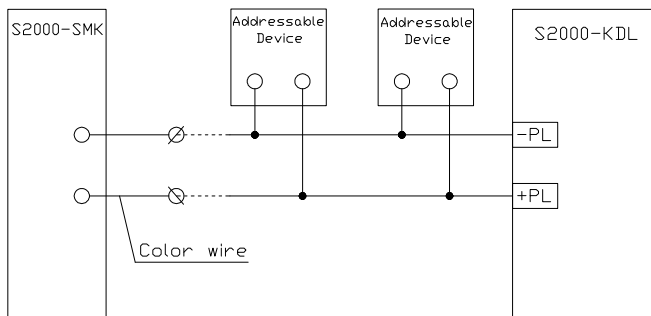

Figure 1: S2000-SMK Wiring Diagram

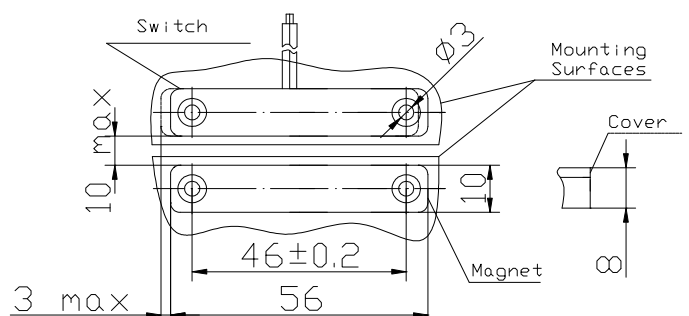

Figure 2: S2000-SMK Mounting Dimensions

The S2000-SMK is to be brought into the S2000-KDL controlled two-wire addressable multiplex polling loop (PL) as shown in Figure 1. The contact is used with such Zone Types as 4, Intrusion and 7, Entrance (states Norm and Intrusion Alarm) as well as 6, Auxiliary (states Auxiliary Zone Alarm and Auxiliary Zone Restored). Zone types and programming procedures are described in S2000-KDL, S2000(M), and Orion Pro software user's manuals.

A magnetic contact involves two components. The first component, a magnet, is screw mounted on the moving portion of the door or window unit. The second compartment, the actual switch, is screw mounted on the jamb within protected premises. These components are attached in parallel on the supervised surfaces along their break line so they are next to each other when the door or window is closed. The magnet and the switch must be mounted so that the distance between them doesn't exceed 10 mm, the bias along break lines being no more than 3 mm. Mounting dimensions are presented in Figure 2. Remove the magnetic contact covers to get to the mounting holes.

When the magnet is placed nearer than 10 mm to the switch, the S2000-SMK remains the norm status. When the magnet has been moved away from the switch for the distance 25 mm or more, the S2000-SMK enters the alarm status.

### **PROGRAMMING THE S2000-SMK ADDRESS**

Connecting an S2000-SMK to an S2000-KDL it is necessary to assign the magnetic contact to a unique zone (loop address) within the range of 1 to 127 identifying the S2000-SMK within the two-wire multiplex addressable polling loop of the controller.

The address is stored in the S2000-SMK non-volatile memory. Any S2000-SMK comes with the preset address value of 127.

In order to change the address of the magnetic contact, connect the S2000-KDL with the attached S2000-SMK to an S2000(M) console or Orion Pro PC through the RS-485 interface. Then send a Change the Device Address command specifying the old address and the new address of the S2000-SMK. The console or the PC shall display for the S2000-KDL disconnecting the device at the old address and finding the device with the new address.

In order to set the S2000-SMK address in the S2000-KDL polling loop without regard to its current address (for example, when the same address is assigned to two or more addressable devices within the loop or when the current device address is unknown), use a Program the Device Address command with the new zone address as the parameter. To do so, issue the command from the console or PC and then twice bring the magnet into proximity with the switch. The console or PC shall display messages about S2000-KDL's disconnecting the device at the old address and finding the device with the new address. If two or more addressable devices had the same address and another address has been programmed for one of them, only the message about finding the device with the new address is displayed.

### **S2000-SMK OPERATING CHECKOUT**

Close the protected door or window, the distance between the magnet and the switch having to be within 10 mm. Arm the zone of the S2000-SMK by means of the S2000(M) console or Orion Pro software.

Move the magnet away from the switch until 45 mm or farther. Ensure the INTRUSION ALARM message along with the relevant zone address has just been displayed by the S2000(M) or PC.

If no alarm message has been displayed, the magnetic contact seems to be out of order provided that all other equipment is known to be good. Such S2000-SMK should be replaced.



ZAO NVP BOLID

#4 Pionerskaya street, Korolev, Moscow Region, Russia, 141070

Tel./fax +7 495 775-71-55, +7 495 516-93-72

E-mail: [info@bolid.ru](mailto:info@bolid.ru), [overseas@bolid.ru](mailto:overseas@bolid.ru) Web site: <http://www.bolid.com>