

ADDRESSABLE EXECUTIVE MODULE

S2000-SP4/24 Ver 1.04

INSTRUCTION MANUAL

1 TECHNICAL DATA

1.1 General

1.1.1 This Instruction Manual describes S2000-SP4/24 Addressable Executive Module along with its operation algorithms and characteristics.

1.1.2 The module is used as part of a multipart executive device in fire and intrusion alarm systems under control of an S2000-KDL ver.2.01+ or S2000-KDL-2I ver.1.00+ controller and an S2000M console.

1.1.3 Meeting requirements for sound and light indication of control and indicating equipment is provided together with the S2000-KDL and S2000M.

1.1.4 The module is designed to monitor and control fire dampers, smoke control dampers, deluge valves, and other executive devices.

1.1.5 The module is to be attached at a suitable place (on a wall, above a suspended ceiling, or on another constructions near the connected executive device) protected against atmospheric fallouts, mechanical damage, and unauthorized access. The module is designed for round-the-clock operation.

1.1.6 The module must not be used in aggressive medium or dust condition, or in explosion-hazardous premises.

1.1 Specifications

Table 1. Specifications

1) Input Voltage	
Communication Part	– 8 V to 12 V via the polling loop
Executive Part	– An external power supply, 10.2 V to 28.4 V ac/dc
2) Insulating Voltage of the Polling Loop and Executive Part	– Up to 500 V
3) Consumed Current:	
Communication Part	– 1.5 mA max
Executive Part	– 200 mA max(without regard to output's current)
4) Outputs	– 2
5) Max Switching Current per an Output	– 3 A
6) Switching Voltage	– Up to 28 V
7) Circuit Control Current	– 0.5 mA max
8) Monitored Limit Switches	– 2
9) Pre-Operation Time	– 15 s max
10) Operating Temperatures	– Minus 30°C to +55°C
11) Humidity	– 93 % at +40°C
12) Overall Dimensions	– 156 mm × 107 mm × 39 mm
13) Weight	– 0.2 kg max
14) Ingress Protection Rating	– IP20 – IP30, if wall mounted

1.2 Standard Delivery

Table 2. Standard Delivery

Item	Q-ty
S2000-SP4/24 Addressable Executive Module	1
Instruction Manual	1
Woodscrews	3
Wall Plugs 6x30	3
Flat Head Tapping Screw 2.2x6.5	1
MF 1/4W-8k2-5% Resistor	7
Package	1

2 OPERATION

2.1 Outputs

2.1.1 The module provides control of their outputs in accordance with a given executive program under receiving commands sent via the polling loop from the connected S2000-KDL controller. The module also provides monitoring the connected executive circuits for open / short circuit failures.

2.1.2 The module executes commands to switch the outputs on and off for a programmed time.

Note: In state of an open or short circuit failure at the moment of receiving a command to switch on, an output will not be switched on.

2.1.3 States of an output are defined by the voltage on the terminals of the output relative to the ‘-’ terminal of the power input:

Table 3. States of an Output

Circuit Condition	Output State	+ [R] Terminal	- [R] Terminal
Norm	On	Input Voltage Value	0.3 V to 0.9 V
	Off	0.35 V to 4.5 V	0.3 V to 0.6 V
Open Failure	On	Input Voltage Value	0 V to 0.3 V
	Off	4.5 V to 5 V	0 V to 0.3 V
Short Failure	On	Input Voltage Value	Input Voltage Value
	Off	0.3 V to 0.6 V	0.3 V to 0.6 V

Note: If an output is switched off, a short circuit failure is defined by a voltage between the output’s terminals which must not exceed 60 mV.

2.1.4 If executive devices with the effective resistance of 250 Ohm to 50 kOhm are to be connected to the module, they should be connected directly without any additional units (see Figure 1).

2.1.5 If the effective resistance of an executive device is less than 250 Ohm, the device must be connected in series with a diode of the relevant wattage (a 1N4007 diode if the operational current does not exceed 1A or a 1N5406 diode if the operational current exceeds 1A) which must be in proximity of the executive device (see Figure 1). If the executive device is powered by an AC power supply, two diodes must be installed back-to-back, in parallel.

2.1.6 If the control voltage is 5 V and the load effective resistance exceeds 50 kOhm (the voltage between terminals of the output exceeds 4 V), a resistor with resistance less than 50 kOhm

and the relevant wattage (8.2 kOhm & 0.25 W is recommended) should be brought in the circuit closely to the executive device, in parallel with it (see Figure 1).

2.1.7 The module provides responding with the current output circuit condition on a request from the connected S2000-KDL.

2.1.8 States of the executive outputs and the controlled circuits connected to them are indicated in the quiescent mode by means of '1' and '2' LEDs on the module's faceplate as shown in Table 4.

Table 4. Indication of Output Status

Circuit Condition	Output Status	Indicator Behavior
Norm	On	Lit steady in green
	Off	Off
Open Failure	On	Double-flashes in yellow once per two seconds
	Off	
Short Failure	On	Flashes in yellow once per two seconds
	Off	

2.2 Limit Switches

2.2.1 The module can monitor states of two connected limit switches (LS).

2.2.2 Limit switches are used to monitor current position of the damper's blades (open / closed).

2.2.3 A limit switch circuit can be in one of the four states which are defined by the circuit resistance. Table 5 shows the ranges of resistance values for relative states of the limit switch circuits.

2.3 TEST Button

2.3.1 The module provides connecting an external button TEST.

2.3.2 The TEST button is designed to test damper operation conditions manually.

2.3.3 To avoid unauthorized actions with the damper, the TEST button is active only if the module is switched to a special test mode.

2.3.4 To switch the module to the test mode, send the relevant command from the network controller specifying the address of the module and the time the module will be being tested for.

2.3.5 The electric circuit of the TEST button can be in one of four available states which are defined by the circuit resistance. Table 5 shows ranges of the resistance values for these four states of the TEST button circuit.

2.3.6 Any electric button – either a push button or a sticky button, with switched or closed contacts can be used as the TEST button.

Table 5. Circuit Conditions of TEST Button and Limit Switches

Circuit Resistance [kOhm]		ADC Values		Circuit Condition	
Min	Max	Min	Max	TEST Button	Limit Switch
0	2	0	85	Short Failure	Short Failure
2	6	86	139	Pushed in	Closed
6	20	140	200	Released	Open
20	∞	201	255	Open Failure	Open Failure

2.4 Power Inputs

2.4.1 The module monitors input power voltage at U1 and U2 inputs during operation.

2.4.2 Status of powering the module is indicated by READY LED.

2.4.3 If power voltage at both power inputs is between 10 V and 28 V, the module enters in the Power Norm mode and the READY LED is lit steady.

2.4.4 When the voltage at any power input comes out of the normal range 10 V to 28 V, the module enters the Power Failed mode.

Table 6. Power Status Indication

First Power Input Status	Second Power Input Status	Indicator Behavior
Failed	Norm	Flashes in green once per four seconds
Norm	Failed	Double-flashes in green once per four seconds
Failed	Failed	Flashes triply in green once per four seconds
Norm	Norm	Lit steady in green

3 INSTRUCTIONS

3.1 Safety Precautions

3.1.1 There are no potential hazard circuits within the module.

3.1.2 Do SHUT OFF the device power before mounting, wiring, or maintaining the module.

3.1.3 Mounting and maintaining the module MUST be performed by qualified engineers.

3.2 Preparation for Using

3.2.1 If necessary, change the module's addresses within the polling loop of the connected S2000-KDL. The addresses of the module must not be the same as addresses of any devices connected to the same polling loop.

3.2.2 Selecting the suitable power supply, be sure that it is able to provide current enough to power all executive devices connected to the module.

3.2.3 If you are going to use the module with a single power supply, the power supply should be connected to both power inputs of the module.

3.2.4 Attach the module at a suitable location (on the wall, or above a suspended ceiling, or on another construction closely to executive devices at places protected against atmospheric fallouts, mechanical damage, and unauthorized access).

3.2.5 Wire the module as shown in Figure 1.

3.2.6 If it is necessary to control an executive device which requires a single control signal (and uses only one module's relay output), the unused module's output is shunted by a resistor of less than 50 kOhm and relevant wattage (8.2 kOhm & 0.25 W is recommended).

3.2.7 Table 7 describes how to connect actuators.

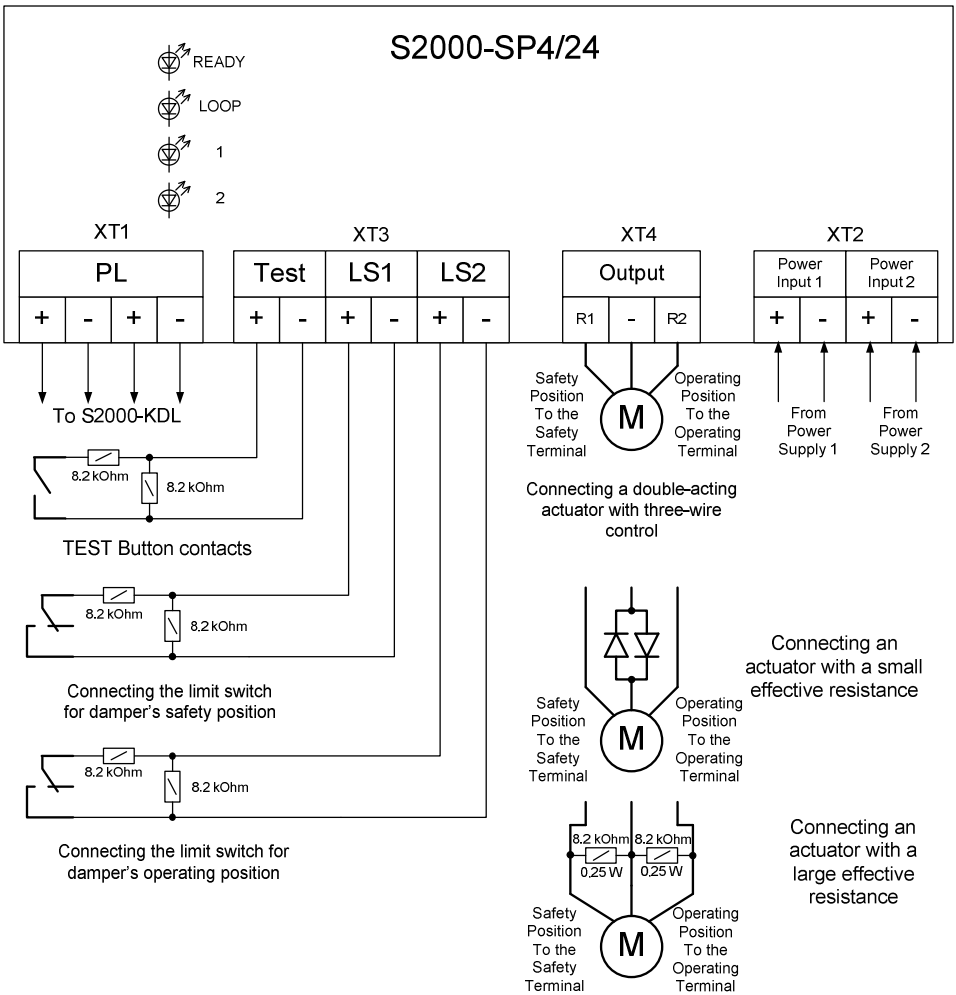

Figure 1. Connection Diagram.

Table 7. How to Connect an Actuator to the S2000-SP4/24

Manufacturer	Article	How to Connect
Belimo	BLF-24	Directly to the required output, the unused output is shunted by a 8.2 kOhm @ 0.25 W resistance
Belimo	BE-24	Directly, without additional elements
Belimo	BLE-24	Directly, without additional elements

3.3 Assigning an Address

The module occupies five addresses within the polling loop of the S2000-KDL and provides storing the addresses in the module's non-volatile memory. The addresses are adjacent, that is the module occupies five addresses in a row, for example (factory values):

Damper address: 123

R1 (Output 1) address: 124

R2 (Output 2) address: 125

LS1 (Limit Switch 1) address: 126

LS2 (Limit Switch 2) address: 127

To assign the addresses, send from the S2000M console or the PC one of the following commands for the S2000-KDL:

- *Program the Device Address;*
- *Change the Device Address.*

Program the Device Address command is used when the current module addresses are unknown or the same addresses are incorrectly assigned to two or more devices. To program the module addresses from the console or the PC, issue the relevant command specifying the required address which is to be assigned with the module. In such case the LOOP LED of the module flashes four times periodically. Within 5 minutes since issuing the command press the tamper switch of the module three times long (>1 s) and once short (<0.5 s). The pause between pressings should be no more than 0.5 s. If a mistake was taken during pressing the combination, next time try to press the tamper switch after 5 s or more. The console or PC will display the events about disconnecting devices with old addresses and finding devices with new programmed addresses. If the devices did have the same addresses, no messages about disconnecting devices with old addresses are displayed.

3.4 Using

The module operates under the connected S2000-KDL controller; all operation conditions (executive program, activation time, activation delay) are specified in the S2000-KDL configuration using UProg software. To use the module, by means of the UProg program set the Device Type in the 'S2000-SP4/24' value for the first of the five addresses which are to be used for the S2000-SP4/24 and, if necessary, associate S2000-KDL zones with outputs on the Dampers tab. The algorithms of setting types of addressable devices and configuration parameters are described at the exploitative documents for S2000-KDL, S2000M, and Orion Pro software.

3.5 Inspecting Module's Operability

3.5.1 Wire the module as described in Clause 3.2.

3.5.2 After supplying power to the PL terminals, the LOOP indicator is lit steady until the S2000-KDL polls the programmed address. Then the LOOP LED flashes with long pauses.

3.5.3 Assign a required address range for the module.

3.5.4 By means of the UProg program, in the configuration of the S2000-KDL assign the first module's address with the S2000-SP4-24 Device Type.

3.5.5 Open the module cover and ensure that a tamper alarm message has been received by the S2000M console or Orion Pro software (a message about tamper recovery should come within 15 seconds after closing the cover).

3.5.6 Further inspection of the module is to be carried out in cooperation with other system components, by issuing damper control commands to the module and logging messages about states of monitored circuits. The system should comprise an S2000M console or a personal computer with installed Orion Pro software and the connected S2000-KDL controller.

3.5.7 Test the damper manually by using the TEST button connected to the S2000-SP4/24 (if connected). To do so, switch the module to the Test Mode, issuing the relevant command from the network controller. Pushing the TEST button (for at least a half of second) will invert the current

damper state. For example, if the damper is in the operating state, pushing the TEST button will run the mechanism of switching the damper to the safety state.

4 MAINTENANCE

Please inspect the module annually by doing the following:

1. Check the S2000-SP4/24 visually for contaminations and mechanical damage
2. Test the S2000-SP4/24 operability as said above
3. Verify the S2000-SP4/24 for secure mounting and wire connection conditions

5 OVERALL AND MOUNTING DIMENSIONS

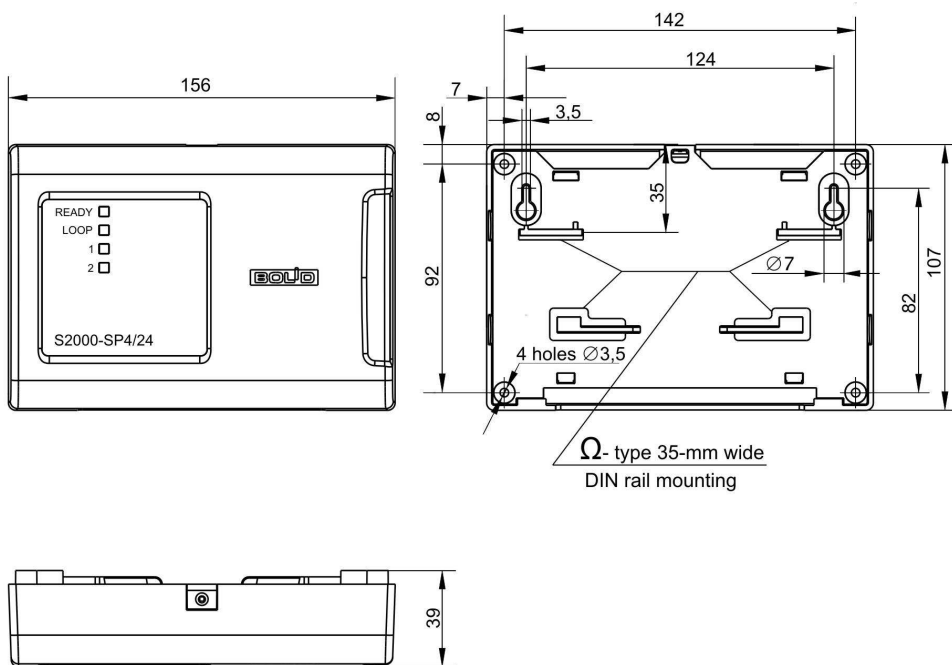

ZAO NVP Bolid, 4 Pionerskaya Str., Korolev 141070,
Moscow Region, Russia

Phone/fax: +7 495 775-7155

Email: info@bolid.ru, overseas@bolid.com

www.bolid.com